

2024

Signage Manual



Memorial University
Interior Signage
Manual 2.0

01 **Introduction**
 The Manual
 General Standards
 Signage Families

02 **A.0 Room Identification**
 A.01 Room ID - A
 A.02 Room ID - B
 A.03 Room ID Public Amenities - B
 A.04 Room ID with Insert - A
 A.05 Room ID with Insert - B
 A.06 Room ID - C

A.1 Regulatory and Safety
 A.10 Location and Egress Plan
 A.11 Public Regulatory and Warning - A
 A.12 Public Regulatory and Warning - B
 A.13 Public Safety Amenities

A.2 Receptacle Identification
 A.21 Receptacle ID - A
 A.22 Receptacle ID - C

A.3 Temporary /Changable Notices
 A.31 Temporary Notices
 A.32 Framing

03 **B.0 Entrance Identification**
 B.01 Entrance ID - Compact
 B.02 Entrance ID - Standard
 B.03 Entrance ID - Large

B.1 Floor Level
 B.11 Floor Level - Compact
 B.12 Floor Level - Standard

B.2 Directional
 B.20 Blade Signage
 B.21 Directional - Standard
 B.22 Directional - Compact
 B.23 Directional - MUNnel

B.3 Directories
 B.31 Building Directories
 B.32 Floor Directories

B.4 Maps
 B.41 Maps

04 **C.0 Title, Dedication & Donor**
 C.01 TD&D - A
 C.02 TD&D - B
 C.03 Donor

C.1 Infographics
 Info
 Graphics

C.2 Surface Colour & Graphics

C.3 Glass Film
 C.30 Linear - Strip Vertical
 C.31 Linear - Strip Horizontal
 C.32 Linear - Band Vertical
 C.33 Linear - Band Horizontal
 C.34 Privacy - Band
 C.35 Privacy - Band Gradient
 C.36 Privacy - Full
 C.37 Privacy - Full Gradient
 C.38 Rib - Strip
 C.39 Rib - Band
 C.40 Rib - Band Gradient
 C.41 Rib - Full Gradient
 C.42 Coast - Strip
 C.43 Coast - Band
 C.44 Coast - Band Gradient
 C.45 Coast - Full Gradient
 C.46 Route - Strip
 C.47 Route - Band
 C.48 Route - Band Gradient
 C.49 Route - Full Gradient
 C.50 Linear - Black Lines
 C.51 Rib - Black Lines
 C.52 Coast - Black Lines
 C.53 Route - Black Lines

Types
 A - Standard
 B - Portrait
 C - Linear

Purpose of Manual

This manual is intended to itemize the Memorial University of Newfoundland's interior signage components and related materials in an easy to follow format. It will detail their application, usage, materials, and outline manufacturing. It will cover the application of graphics and the maintenance of these products.

Importance of Signage

The signage of an area is an important aspect of an institution's visual identity. The different signage elements, of which it is composed, associate the principal function of information and orientation with image confirmation. Signage must organize space by defining the direction and flow of users as well as their behaviour across a common area. The development of interior signage standards demonstrates the desire for improvement and constant modernization of Memorial University. The standardization of the signage system brings coherence, flexibility and visual harmony to the entirety of the campuses.

In wanting to establish and define interior signage standards in all buildings across campuses, Memorial University is proud to publish this document, in which are discussed principles and guidelines to follow.

Purpose of Signage

The purpose of signage is to guide users comfortably and clearly, using legible information which can be understood universally. For visitors, students and employees, signage at Memorial University must be informative, navigable, and inclusive, communicating a welcoming and structured image throughout the campus.

Our Identity

Memorial University's identity reflects the idea of transformation, offering the freedom to explore and experience your ingenuity. It is inspired by the raw beauty of the province, by our ingenuity in thriving in challenging circumstances, by the unique educational experiences we offer and by freedom, for Memorial University was built in homage to fallen war heroes and embraces at its core the spirit of freedom. In other words, Memorial is the natural place for people and ideas to become.

The Design

The design is based on current code requirements and accessibility standards closely coordinated between Facilities Management, Marketing and Communications to maintain the university brand standards.

Refer to the Facilities Management website for chargeable vs. non-chargeable signage:

www.mun.ca/facilities-management

Policies

Signage must comply with Memorial University's policies and procedures, which include (but are not limited to) the Student Code of Conduct, the Sexual Harassment and Sexual Assault Policy, the Respectful Workplace Policy and, where appropriate, the Procedure for Alcohol-related Advertising.

Any signage deemed to be in violation of any university policy or procedure, or which is deemed to be non-university related, will be removed immediately. The university reserves the right to remove signage at any time.

Requests

[Signage Request](#)

[Display a Flag Form](#)

Resources

[Brand Standards](#)

[Mun.ca Brand Colours](#)

[Flag Policy](#)

[Visual Identity Policy](#)

[Poster Guidelines](#)

[CNIB Standards](#)

[Accessible Signage Guidelines](#)

[Smoking Policy](#)

[Indigenous Translations](#) (future)

[Room Numbering](#) (future)

[Insert Templates](#) (future)

Claret

Pantone 202 is Memorial University's colour found in the logo along with Pantone Cool Grey 10

Signage Use

Signage needs to be of contrast such that visitors with visual impairments can identify and read the text on signage. Print letters and numerals need to have a tonal contrast of at least 70% with their background and be finished with a matte or glare-free surface.* This allows visitors with limited visual capacity to still determine signage even if they cannot read the copy and may need to physically adjust their distance.

Primary



Claret
PMS 202
C0 M100 Y61 K43
R134 G38 B51
HEX 862633



Cool Grey 10
C61 M53 Y48 K19
R99 G102 B106
HEX 63666A



Cool Grey
(Specialized)
C43 M35 Y35 K1
R151 G153 B155
HEX 97999B



Warm Grey 6
C36 M35 Y38 K1
R165 G156 B148
HEX A59C94



Warm Grey 8
C45 M44 Y48 K7
R140 G130 B121
HEX 8C8279



Charcoal (Garbage)
C0 M0 Y0 K90
R65 G64 B66
HEX 404041



Black
C30 M20 Y20 K100
R35 G31 B32
HEX 231F20



White (Paper)
C0 M0 Y0 K0
R255 G255 B255
HEX FFFFFFFF

**Notices & Coding



PMS 185
(Prohibition)
C1 M100 Y92 K0
R228 G0 B43
HEX E4002B



Yellow (Warning/
Hazardous)
C0 M4 Y100 K0
R255 G221 B0
HEX FEDD00



PMS 2736
(Mandatory/Plastic)
C100 M91 Y0 K0
R48 G127 B170
HEX 1E22AA



Green PMS 341c
(Safe Cond./Compost)
C95 M5 Y82 K24
R0 G122 B83
Avery Bright Green
SC 900-722-0

Glass Film



Polymeric Etch Film
Lead Crystal
C24 M20 Y27 K0
R195 G191 B180
HEX C2BFB5
PMS 20-0087

MUNnel



MUNnel Orange
Orange 021
C0 M82 Y100 K0
R254 G80 B0
HEX FE5000



MUNnel Yellow
C1 M37 Y100 K0
R249 G171 B0
HEX F9AB00



MUNnel Blue
PMS 2935c
C100 M52 Y0 K0
R0 G87 B184
3M Intense Blue
220-47



MUNnel Green
C95 M5 Y82 K24
R0 G122 B83
Avery Bright Green
SC 900-722-0

Secondary Palette



Rhodamine Red
C5 M97 Y1 K0
R225 G0 B152
HEX E10098



PMS 185
C1 M100 Y92 K0
R228 G0 B43
HEX E4002B



Orange 021
C0 M82 Y100 K0
R254 G80 B0
HEX FE5000



PMS 1235
C0 M32 Y95 K0
R255 G184 B28
HEX FFB81C



Yellow
C0 M4 Y100 K0
R255 G221 B0
HEX FEDD00



PMS 396
C16 M1 Y100 K0
R225 G224 B0
HEX E1E000



PMS 368
C57 M0 Y100 K0
R120 G190 B32
HEX 78BE20



PMS 3275
C95 M0 Y47 K0
R0 G179 B152
HEX 00B398



PMS 3125
C83 M0 Y21 K0
R0 G174 B199
HEX 00AEC7



PMS 2727
C71 M42 Y0 K0
R48 G127 B226
HEX 307FE2



PMS 2736
C100 M91 Y0 K0
R48 G127 B170
HEX 1E22AA



PMS Purple
C34 M88 Y0 K0
R187 G41 B187
HEX BB29BB

Facilities Management Palette



Benjamin Moore
New Lime
2025-30



Benjamin Moore
Neon Red
2087-10



Benjamin Moore
Naples Blue
2057-30



Benjamin Moore
Yellow Flash
2021-10



Benjamin Moore
Starry Night Blue
2067-20



Benjamin Moore
Pre-Dawn Sky
2075-30

*2023 Canadian Standards Association
**2006 Canadian Standards Association CFW/CSA-Z321-96

Purpose

High level understanding of how the signage family works in tandem

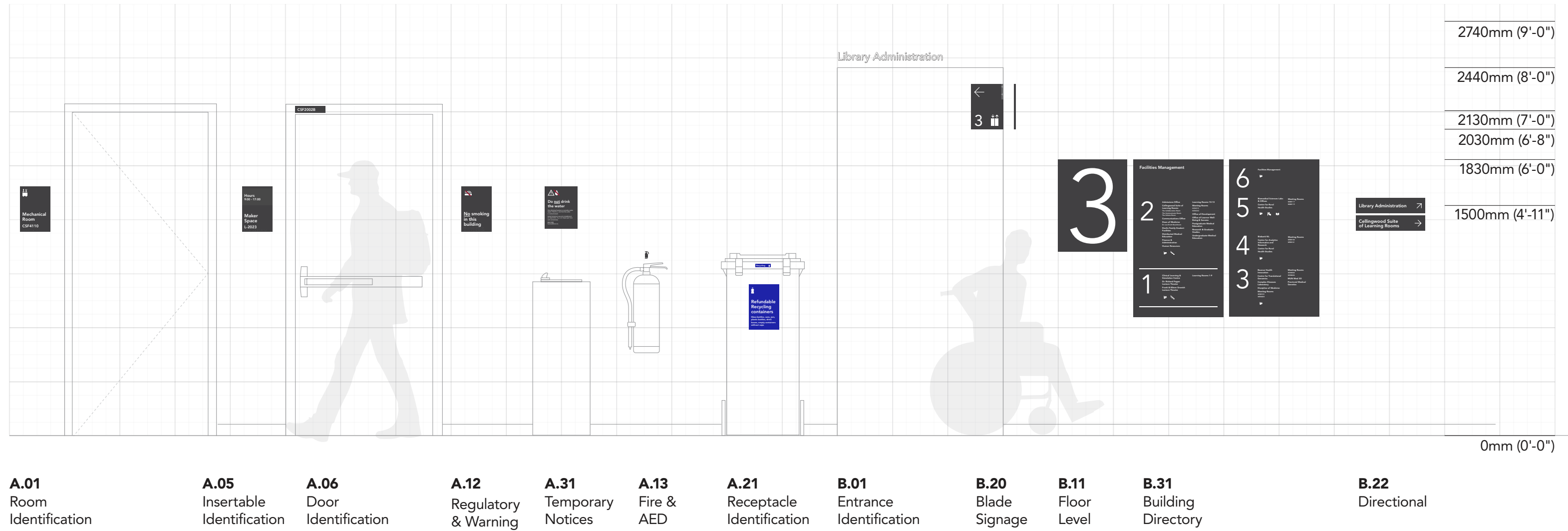

Front View

Scale: 1:25

Purpose

High level understanding of how the signage family works in tandem

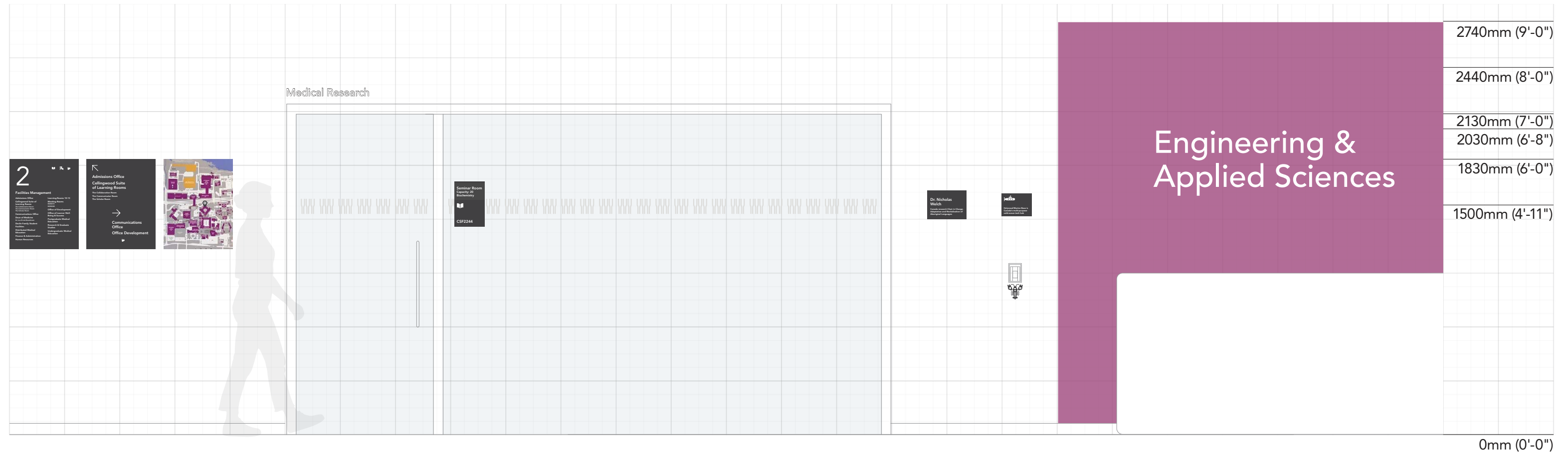

B.32
Floor
Directory

B.21
Directional

B.41
Maps

B.01
Entrance
Identification

A.05
Room
Identification

C.38
Glass Film

C.01
Donor &
Dedication

C.1
Infographic

C.2
Surface
Colour

B.03
Entrance
Identification

Front View

Scale: 1:25

A.01 Room ID - A

Standard

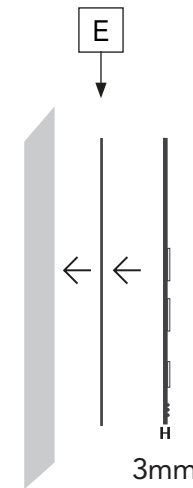
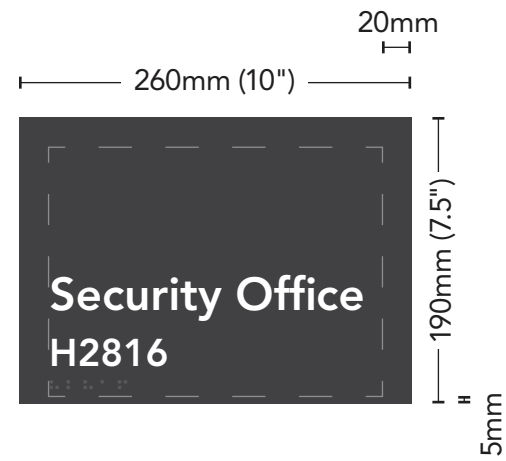

1 Layout

Scale: 1:5

2 Section

Scale: 1:5

Description

- A** 3mm-thick acrylic panel; Charcoal colour; Returns to match panel colour; Mounted to wall surface securely
- B** Avenir LT Std; 85 Heavy; 22.5mm cap-height; Optical kerning; Tracking (0); Left aligned; White; Raised 0.8mm from panel
- C** Avenir LT Std; 85 Heavy; 18mm cap-height; Optical kerning; Tracking (0); Left aligned; White; Raised 0.8mm from panel
- D** Braille; 10mm cap-height; Colour to match panel; Raised 0.8mm from panel; Message to include both room name and room number
- E** When mounted to glass surface, vinyl backer to be applied to same side of glass as sign to hide adhesive; Backer to match sign colour

Use

Sign for standard room identification with a fixed use, ie. Custodial Rooms, Mechanical Rooms, Security Office.

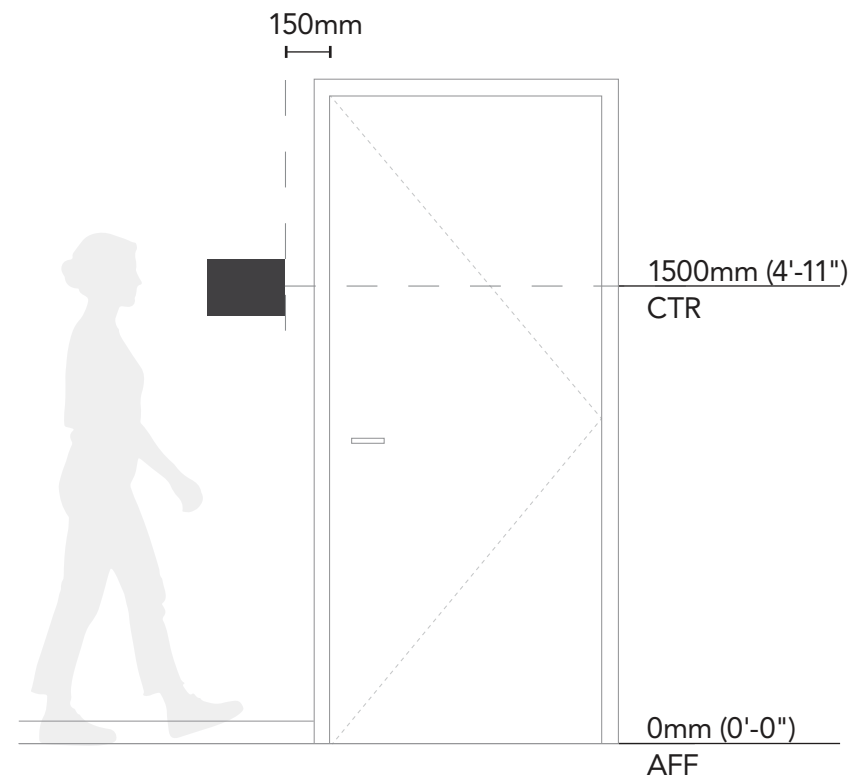

3 Elevation

Scale: 1:25

A.02 Room ID - B

Portrait

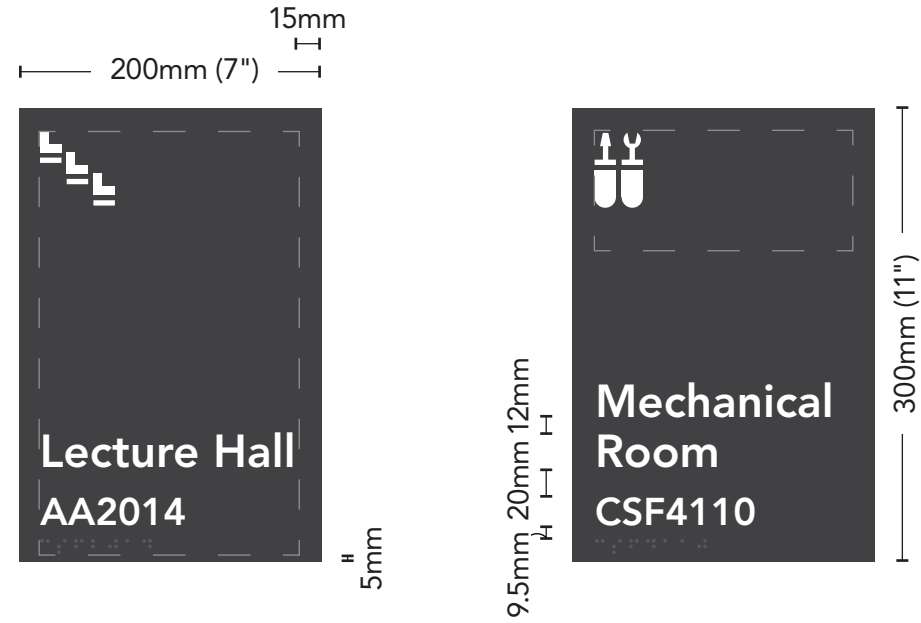

1 Layout

Scale: 1:5

Introduction

Signage

Wayfinding

Branding

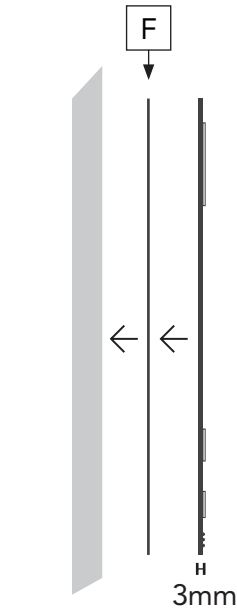
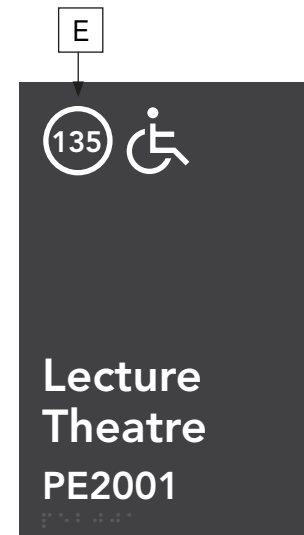
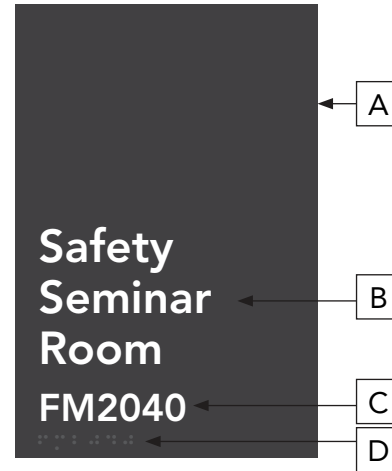

2 Section

Scale: 1:5

Description

- A** 3mm-thick acrylic panel; Charcoal colour; Returns to match panel colour; Mounted to wall surface securely
- B** Avenir LT Std; 85 Heavy; 22.5mm cap-height; Optical kerning; Tracking (0); Left aligned; White; Raised 0.8mm from panel
- C** Avenir LT Std; 85 Heavy; 18mm cap-height; Optical kerning; Tracking (0); Left aligned; White; Raised 0.8mm from panel
- D** Braille; 10mm cap-height; Colour to match panel; Raised 0.8mm from panel; Message to include both room name and room number
- E** Pictogram; White; Direct print or vinyl; Size relative to signage layout in scale
- F** When mounted to glass surface, vinyl backer to be applied to same side of glass as sign to hide adhesive; Backer to match sign colour

Use

Sign for standard room identification with a permanent description and additional icon/pictogram for added clarity and information. Used for public rooms, accessed by more than one unit with a fixed use, ie. Lecture Rooms, Classrooms.

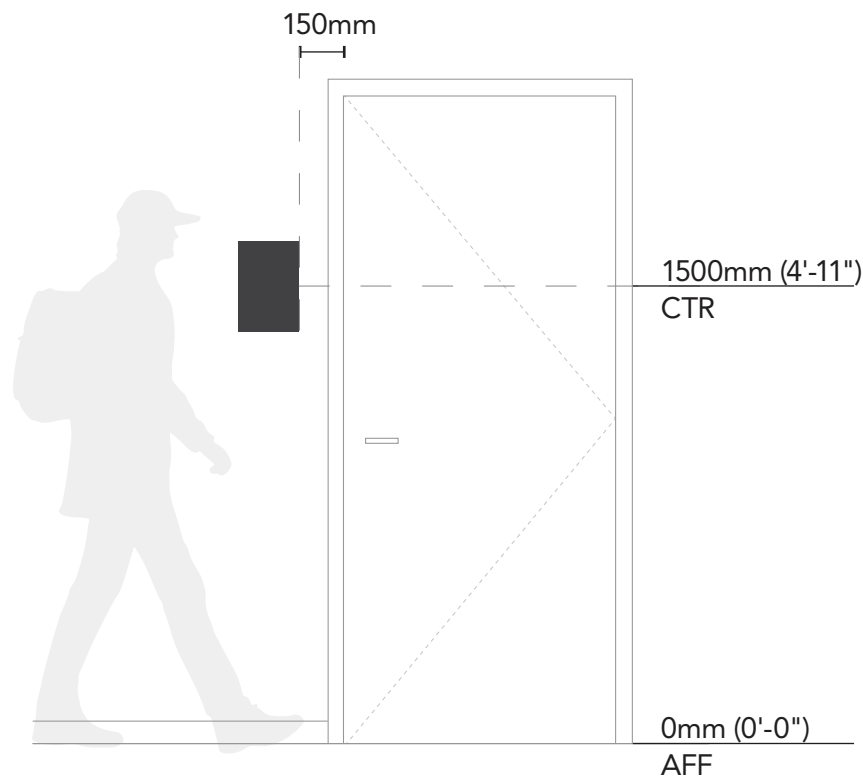

3 Elevation

Scale: 1:25

A.03 Room ID Public Amenities - B

Restroom

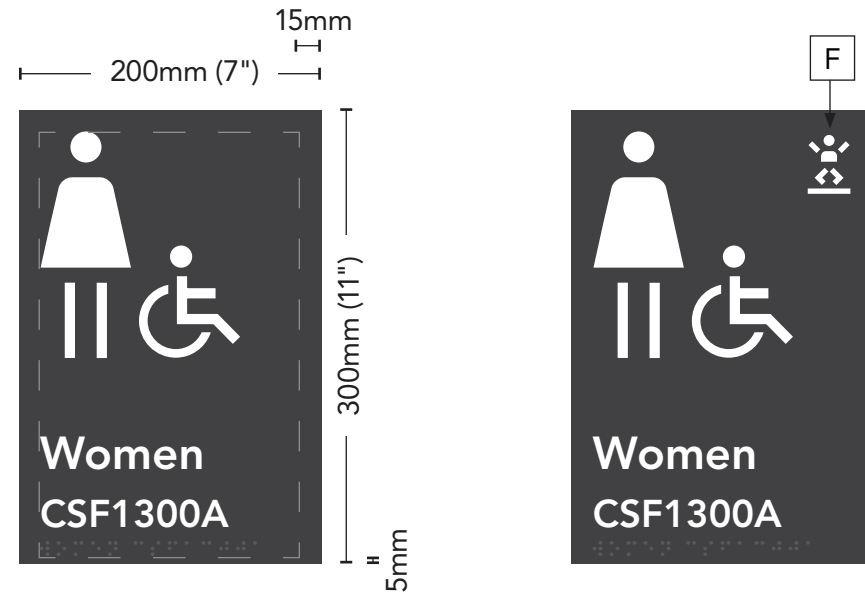

1 Layout
Scale: 1:5

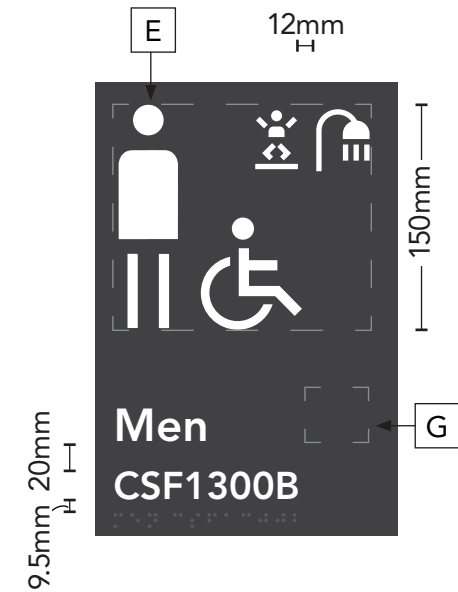

Introduction

Signage

Wayfinding

Branding

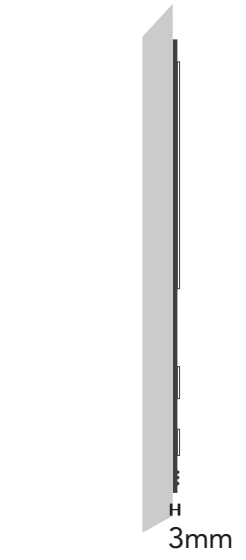
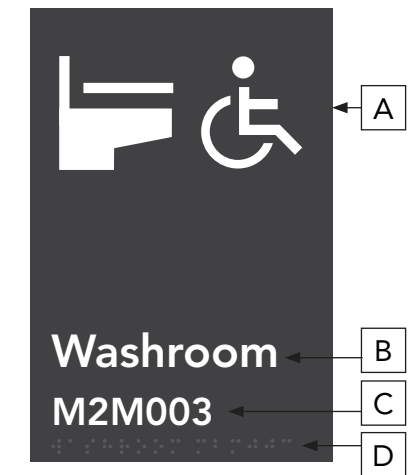

2 Section
Scale: 1:5

Description

- A** 3mm-thick acrylic panel; Charcoal colour; Returns to match panel colour; Mounted to wall surface securely
- B** Avenir LT Std; 85 Heavy; 22.5mm cap-height; Optical kerning; Tracking (0); Left aligned; White; Raised 0.8mm from panel
- C** Avenir LT Std; 85 Heavy; 18mm cap-height; Optical kerning; Tracking (0); Left aligned; White; Raised 0.8mm from panel
- D** Braille; 10mm cap-height; Colour to match panel; Raised 0.8mm from panel; Message to include both room name and room number
- E** Pictogram; White; Raised 0.8mm from panel
- F** Pictogram; White; Direct print or Vinyl; Size relative to signage layout in scale
- G** Avenir LT Std; 65 Medium; 7.5mm cap-height; Optical kerning; Tracking (0); Left aligned; White; Direct print or vinyl; (future)

Use

Sign for public amenity room identification, including pictogram, permanent description, braille translations of the description, ie. Elevators, Stairs, Washroom.

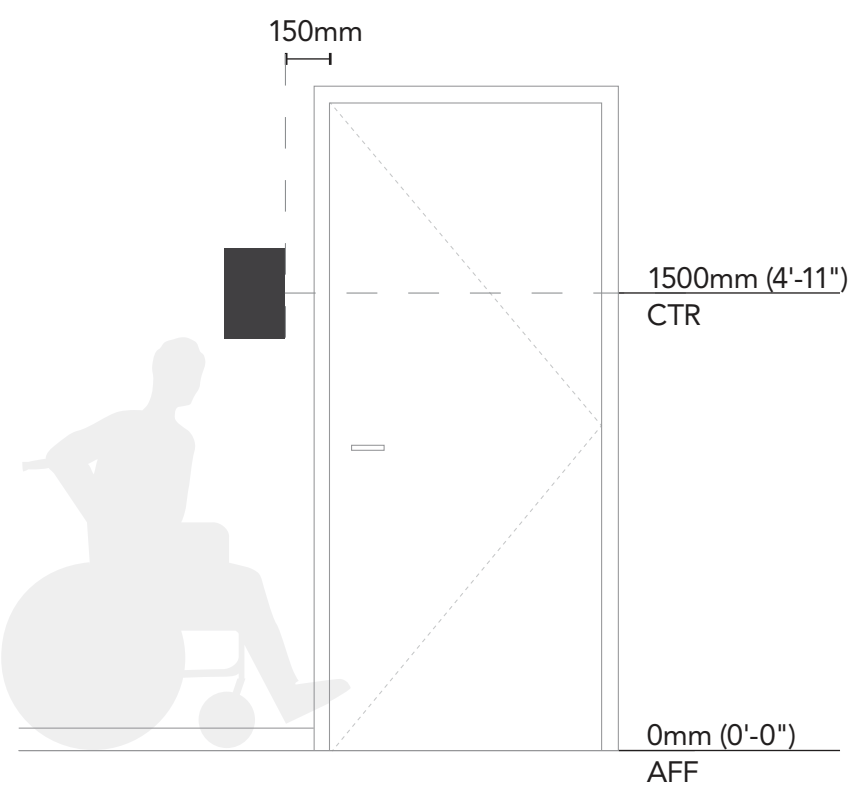

3 Elevation
Scale: 1:25

A.03 Room ID Public Amenities - B

Circulation

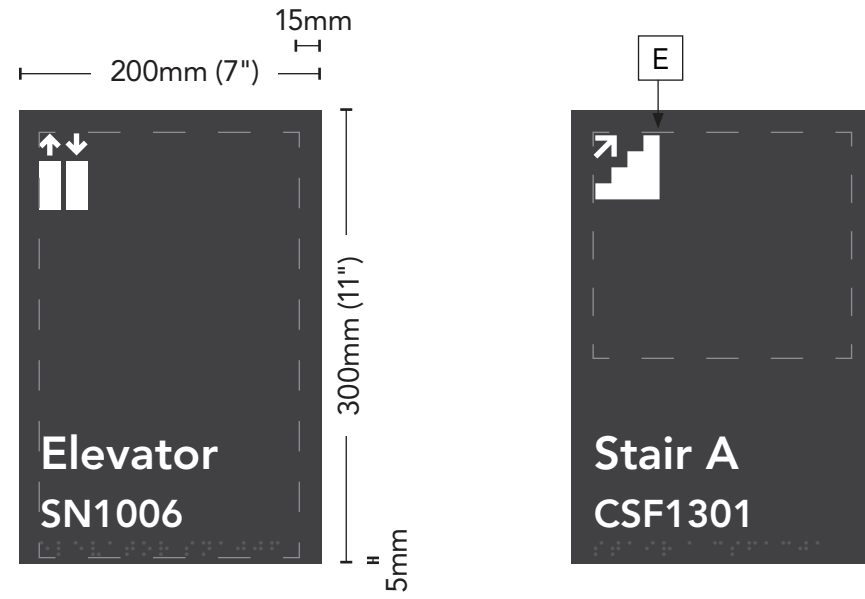

1 Layout

Scale: 1:5

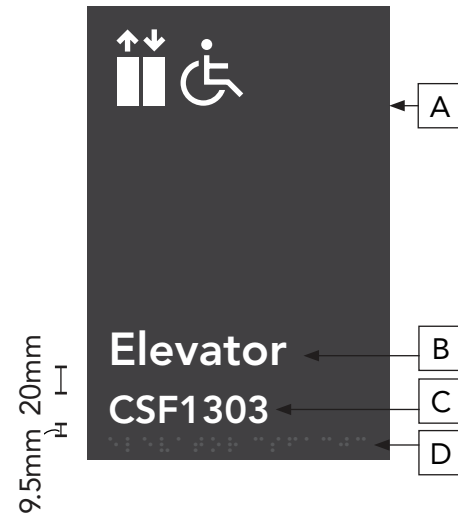

2 Section

Scale: 1:5

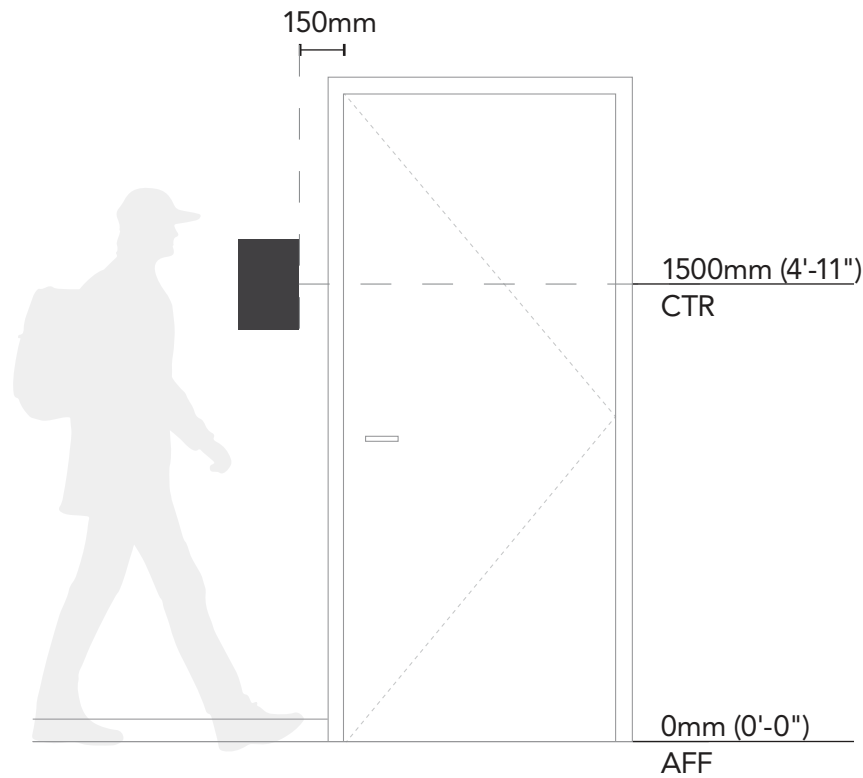
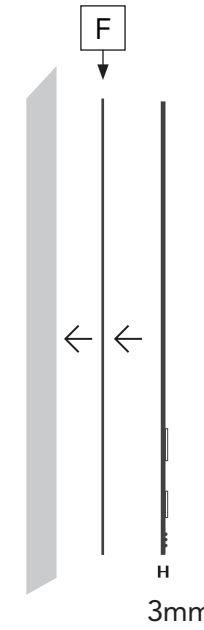

3 Elevation

Scale: 1:25

Description

- A** 3mm-thick acrylic panel; Charcoal colour; Returns to match panel colour; Mounted to wall surface securely
- B** Avenir LT Std; 85 Heavy; 22.5mm cap-height; Optical kerning; Tracking (0); Left aligned; White; Raised 0.8mm from panel
- C** Avenir LT Std; 85 Heavy; 18mm cap-height; Optical kerning; Tracking (0); Left aligned; White; Raised 0.8mm from panel
- D** Braille; 10mm cap-height; Colour to match panel; Raised 0.8mm from panel, Message to include both room name and room number
- E** Pictogram; White; Direct print or vinyl; Size relative to signage layout in scale
- F** When mounted to glass surface, vinyl backer to be applied to same side of glass as sign to hide adhesive; Backer to match sign colour

Use

Sign for public amenity room identification, including pictogram, permanent description, braille translations of the description, ie. Elevators, Stairs, Washrooms.

A.04 Room ID with Insert - A

Standard

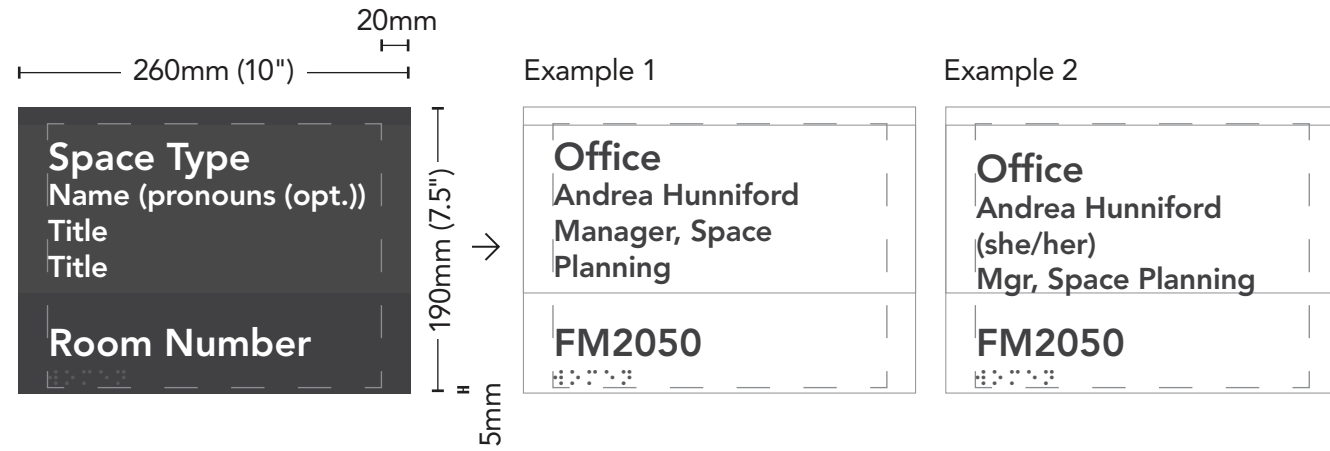

1 Layout

Scale: 1:5

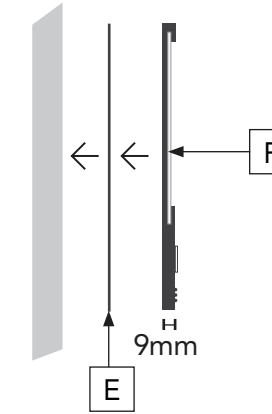

2 Section

Scale: 1:5

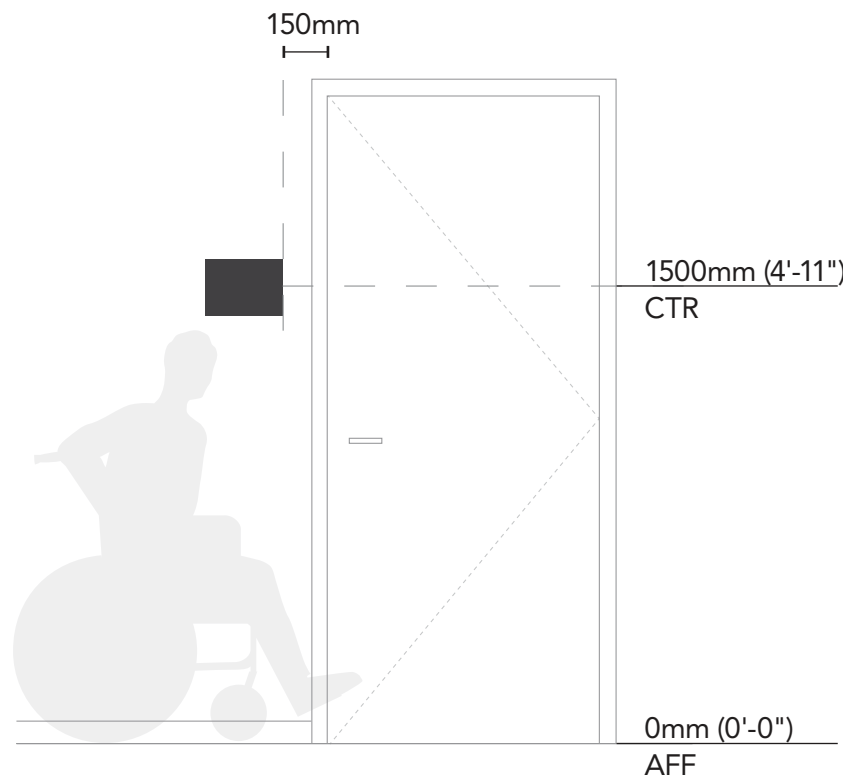

3 Elevation

Scale: 1:25

Description

- A** 9mm-thick acrylic panel; Charcoal colour; Returns to match panel colour; Mounted to wall surface securely
- B** Avenir LT Std; 85 Heavy; 18mm cap-height; Optical kerning; Tracking (0); Left aligned; White; Raised 0.8mm from panel (not on inserts)
- C** Avenir LT Std; 85 Heavy; 14mm cap-height; Optical kerning; Tracking (0); Left aligned; White; Printed
- D** Braille; 10mm cap-height; Colour to match panel; Raised 0.8mm from panel; Message to include both room name and room number
- E** When mounted to glass surface, vinyl backer to be applied to same side of glass as sign to hide adhesive; Backer to match sign colour
- F** White cardstock insert printed with background to match panel

Use

Sign for offices and small meeting room identification, where a paper insert is used to identify the room type, perhaps the occupant, and capacity description, all as per the insert template.

A.05 Room ID with Insert - B

Portrait

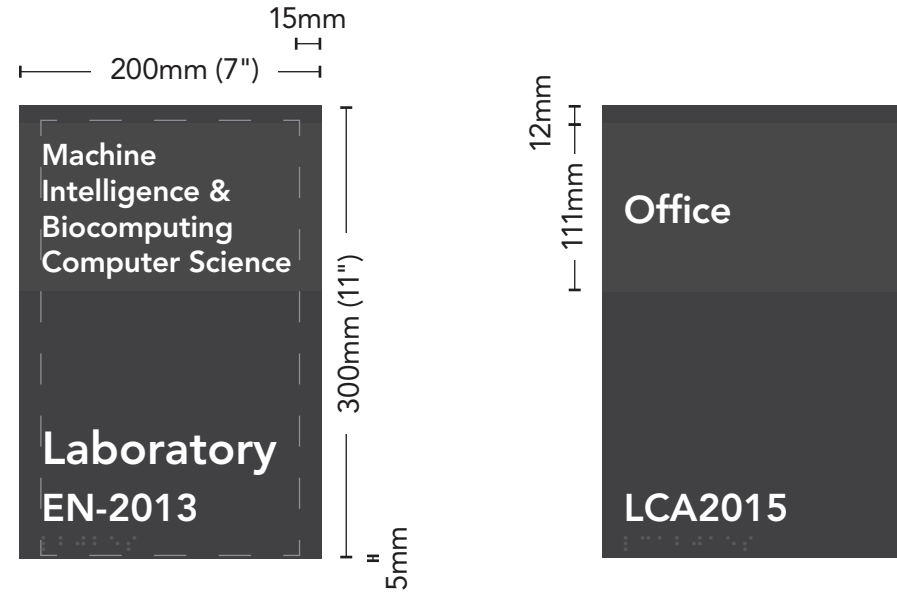

1 Layout

Scale: 1:5

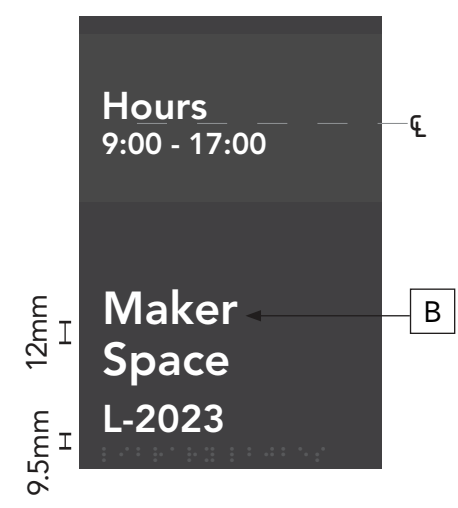
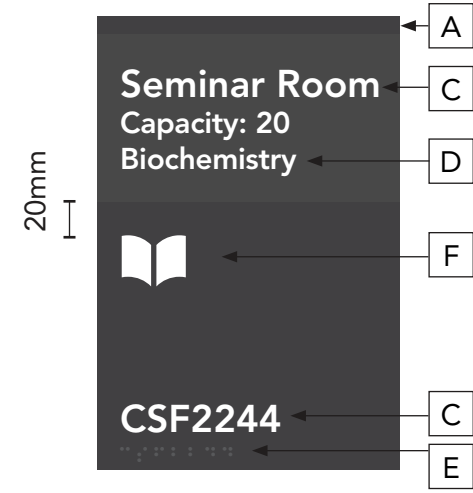

2 Section

Scale: 1:5

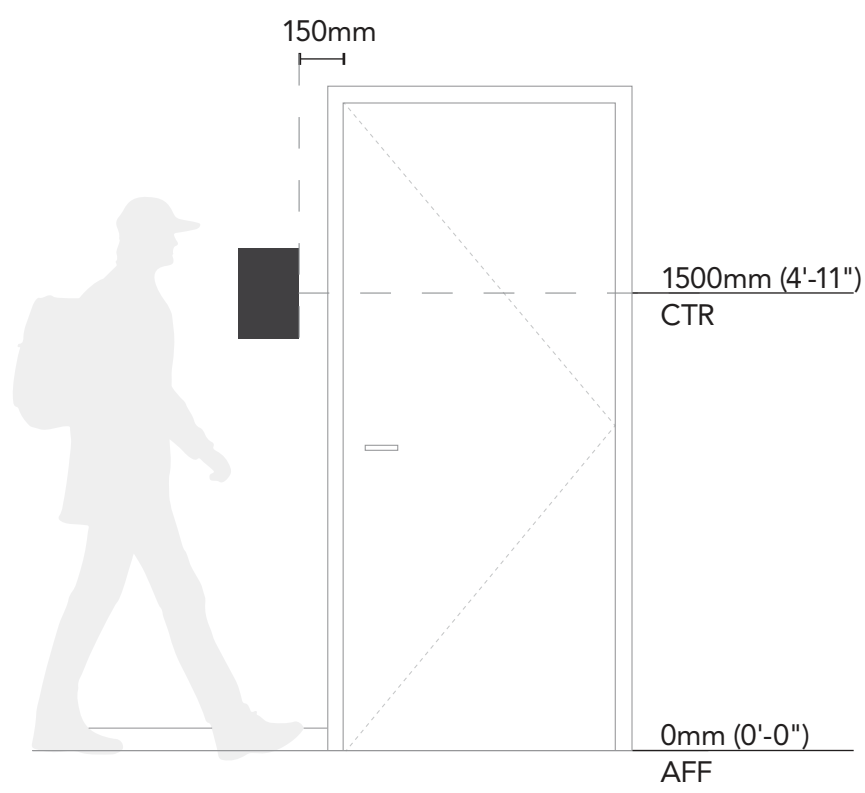
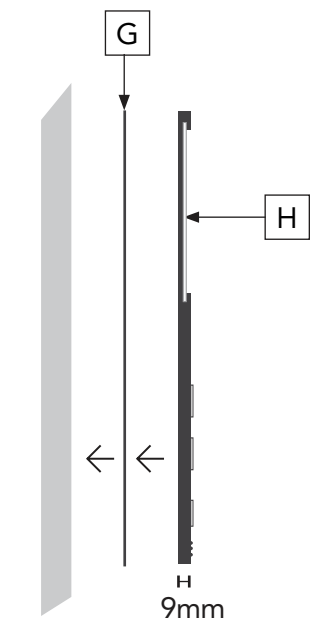

3 Elevation

Scale: 1:25

Description

- A** 9mm-thick acrylic panel; Charcoal colour; Returns to match panel colour; Mounted to wall surface securely
- B** Avenir LT Std; 85 Heavy; 22.5mm cap-height; Optical kerning; Tracking (0); Left aligned; White; Raised 0.8mm from panel
- C** Avenir LT Std; 85 Heavy; 18mm cap-height; Optical kerning; Tracking (0); Left aligned; White; Raised 0.8mm from panel, (not on inserts)
- D** Avenir LT Std; 85 Heavy; 14mm cap-height; Optical kerning; Tracking (0); Left aligned; White; Printed
- E** Braille; 10mm cap-height; Colour to match panel; Raised 0.8mm from panel; Message to include both room name and room number
- F** Pictogram; white; Direct print or vinyl; Size relative to signage layout in scale
- G** When mounted to glass surface, vinyl backer to be applied to same side of glass as sign to hide adhesive; Backer to match sign colour
- H** White cardstock insert printed with background to match panel

Use

Sign for large meeting rooms and public spaces where the sign can be used to identify the room type, perhaps some additional permanent information about the space using pictograms, and the insert can be used to add additional pertinent information as per the insert template.

A.06 Door ID - C

Standard

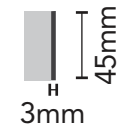
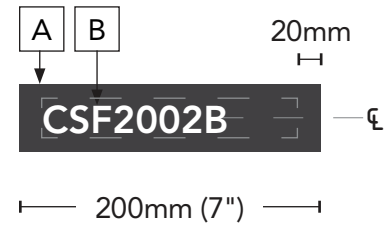

1 Layout

Scale: 1:5

2 Section

Scale: 1:5

Description

- A** 3mm-thick acrylic panel; Charcoal colour; Returns to match panel colour; Mounted to door frame securely
- B** Avenir LT Std; 85 Heavy; 18mm cap-height; Optical kerning; Tracking (0); Left aligned; White; Direct print or vinyl

Use

Sign for when just a room number is required for reference, including closets, small storage rooms, cold rooms, and secondary entrances.

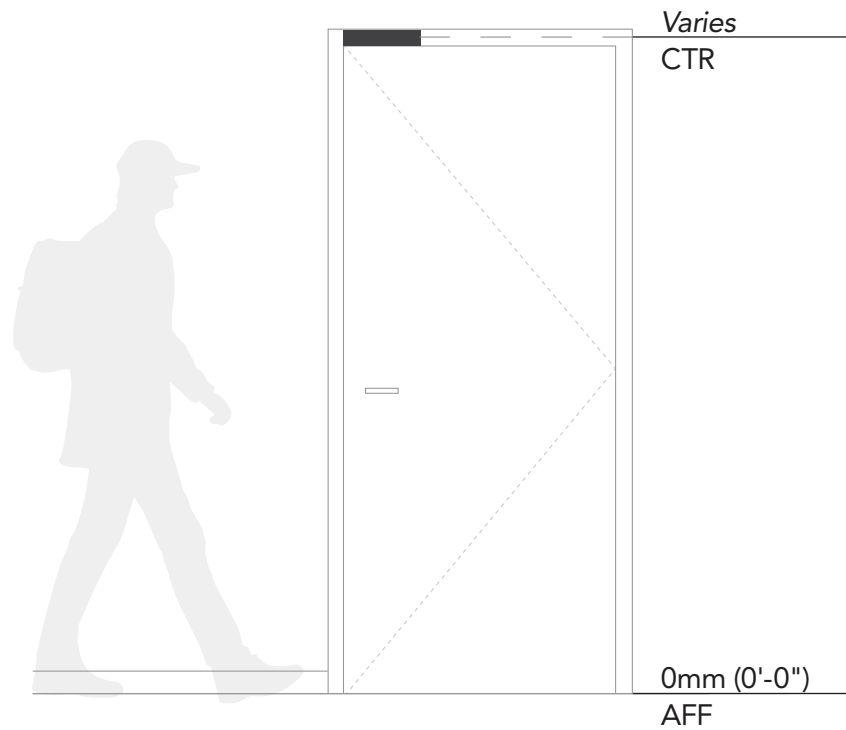

3 Elevation

Scale: 1:25

A.10 Location and Egress Maps

Standard

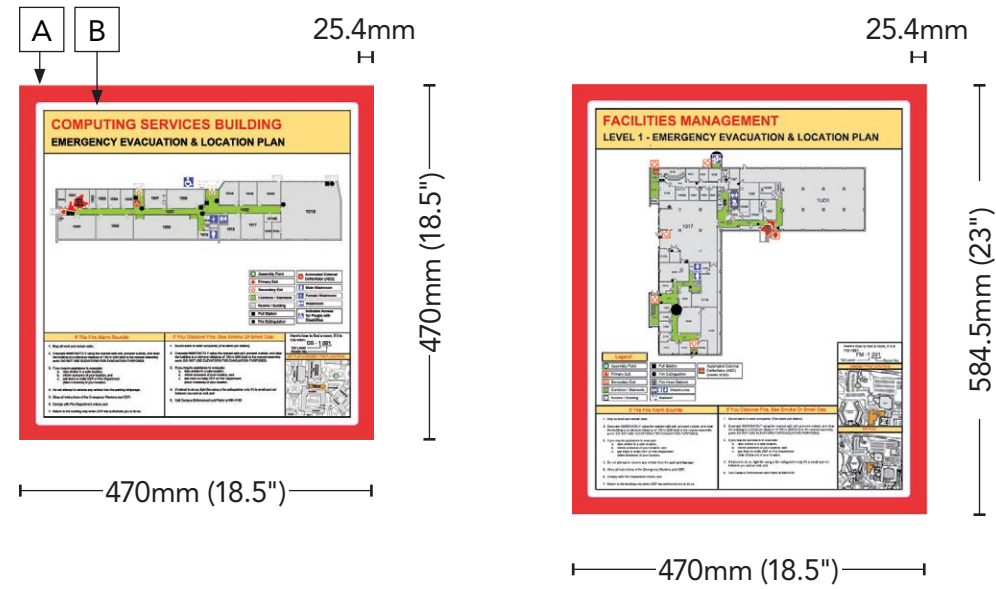

1 Layout
Scale: 1:10

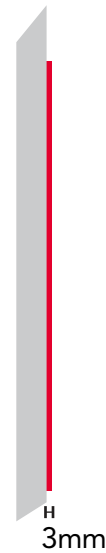

2 Section
Scale: 1:10

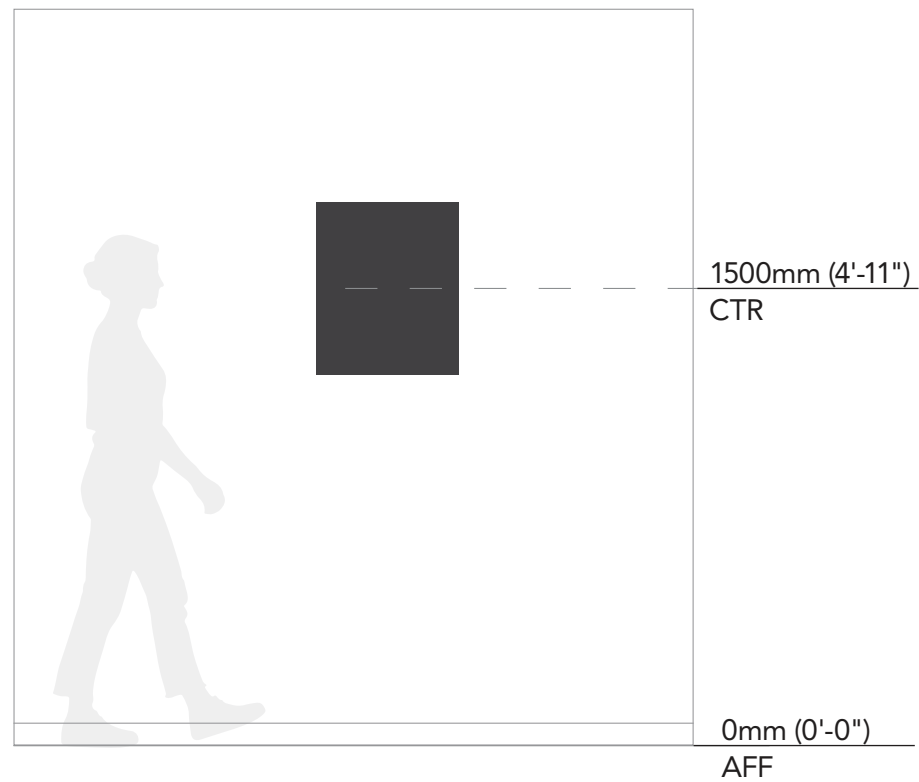

3 Elevation
Scale: 1:25

Description

- A** 3mm-thick acrylic panel or similar; MUN PMS 185 colour; Returns to match panel colour; Mounted securely to surface
- B** Printed vinyl onto acrylic panel or similar

Use

Egress maps help make sure that in the event of an emergency, everyone in the building has a clear evacuation plan.

A.11 Public Regulatory & Warning - A

Standard: Colour Coded

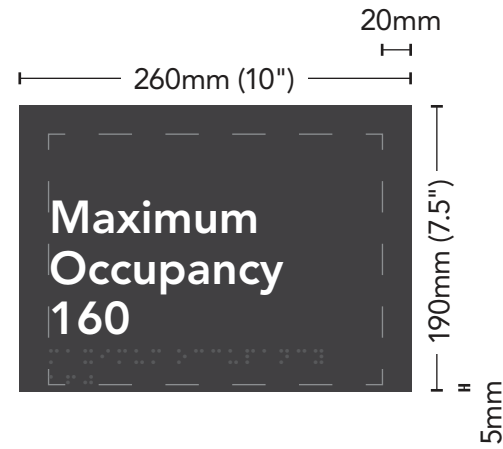

1 Layout
Scale: 1:5

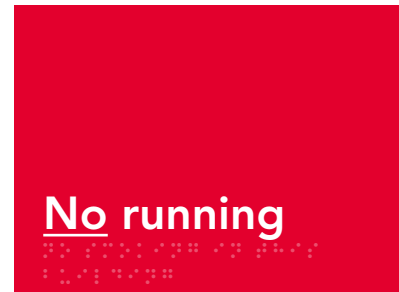

2 Prohibition
Scale: 1:5

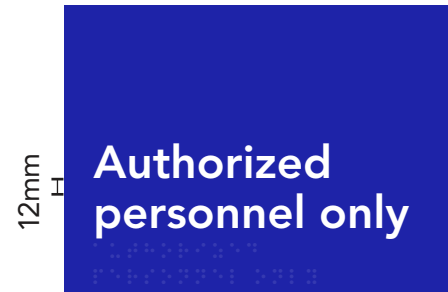

3 Mandatory
Scale: 1:5



4 Warning
Scale: 1:5

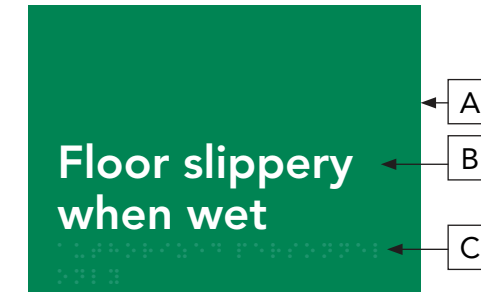

5 Safety
Scale: 1:5

Description

- A** 3mm-thick acrylic panel; colour to change per sign; Returns to match panel colour; Mounted to wall surface securely
- B** Avenir LT Std; 85 Heavy; 22.5mm cap-height; Optical kerning; Tracking (0); Left aligned; White or Black; Raised 0.8mm from panel
- C** Braille; 10mm cap-height; Colour to match panel; Raised 0.8mm from panel
- D** When mounted to glass surface, vinyl backer to be applied to same side of glass as sign to hide adhesive; Backer to match sign colour

Use

Sign for standard public regulatory and warnings, where the sign can be used to communicate different messages, ie. Prohibition, Mandatory, Warning and Safety.

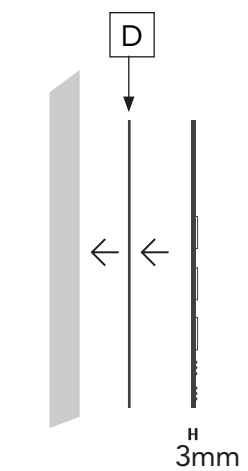

6 Section
Scale: 1:5

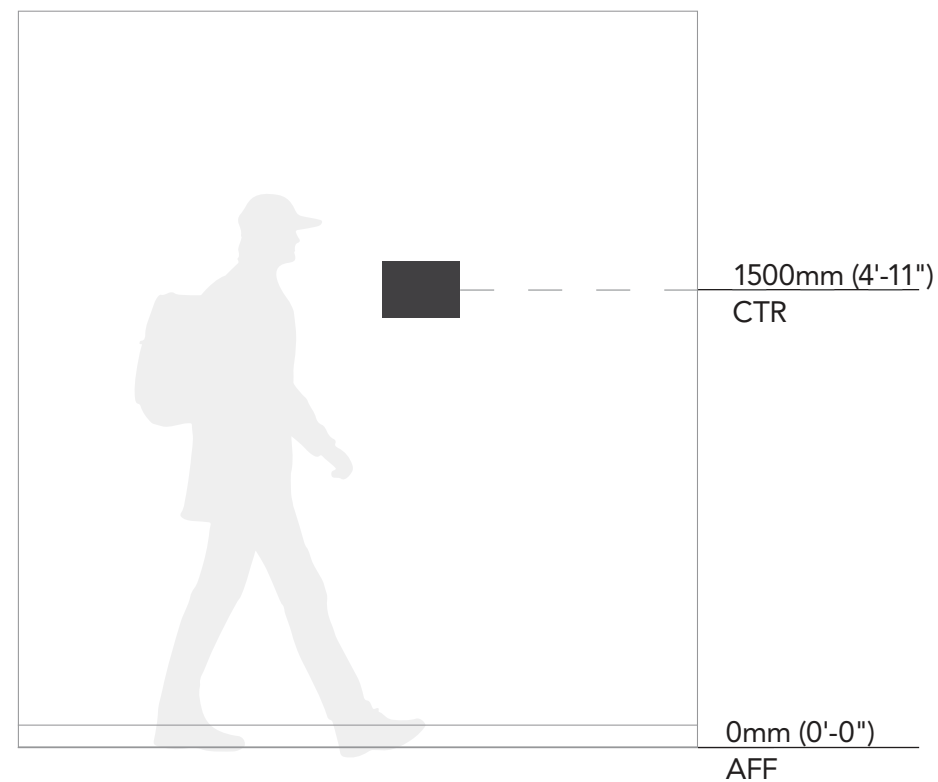

7 Elevation
Scale: 1:25

A.12 Public Regulatory & Warning - B

Portrait: Colour Coded

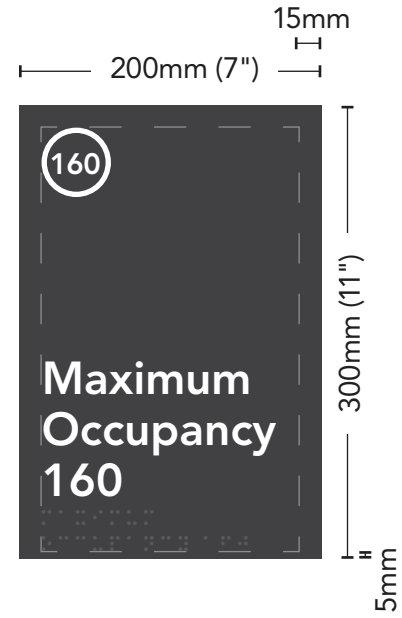

1 Layout
Scale: 1:5



2 Prohibition
Scale: 1:5

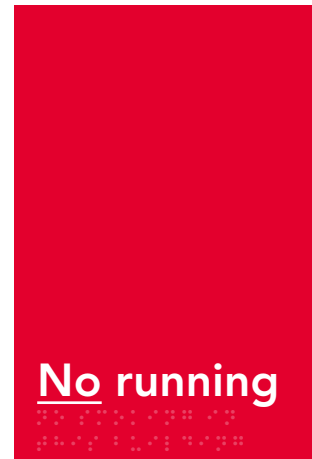

3 Prohibition
Scale: 1:5

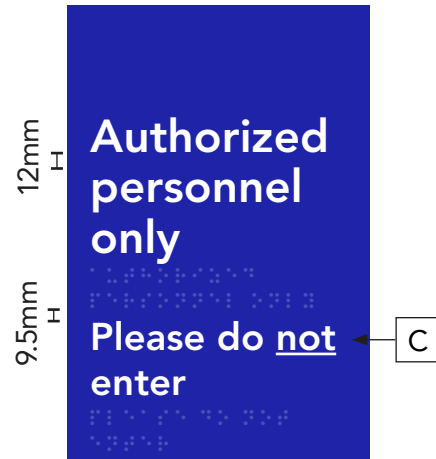

4 Mandatory
Scale: 1:5

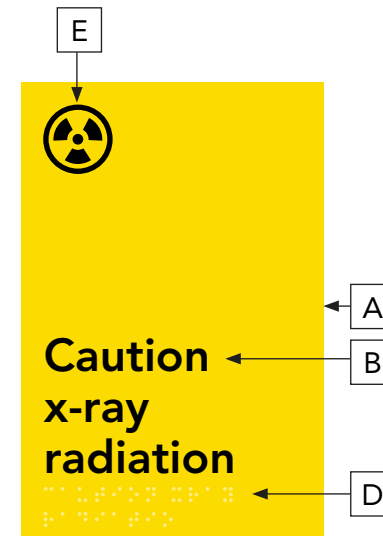

5 Warning
Scale: 1:5

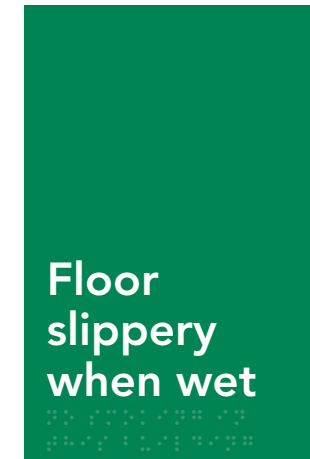

6 Safety
Scale: 1:5

Description

- A** 3mm-thick acrylic panel; colour to change per sign; Returns to match panel colour; Mounted to wall surface securely
- B** Avenir LT Std; 85 Heavy; 22.5mm cap-height; Optical kerning; Tracking (0); Left aligned; White or Black; Raised 0.8mm from panel
- C** Avenir LT Std; 85 Heavy; 18mm cap-height; Optical kerning; Tracking (0); White or Black; Left aligned; Raised 0.8mm from panel
- D** Braille; 10mm cap-height; Colour to match panel; Raised 0.8mm from panel
- E** Pictogram; White or Black; Direct print or vinyl; Size relative to signage layout in scale
- F** When mounted to glass surface, vinyl backer to be applied to same side of glass as sign to hide adhesive; Backer to match sign colour
- G** Poster frame; Black aluminum or similar

Use

Sign for standard public regulatory and warnings, where the sign can be used to communicate different messages, ie. Prohibition, Mandatory, Warning and Safety; perhaps some additional permanent information about the content using pictograms, can be used to add additional pertinent information.



7 Frame
Scale: 1:5

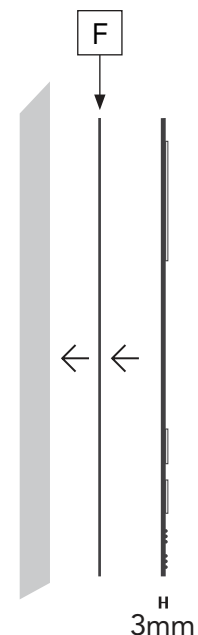

8 Section
Scale: 1:5

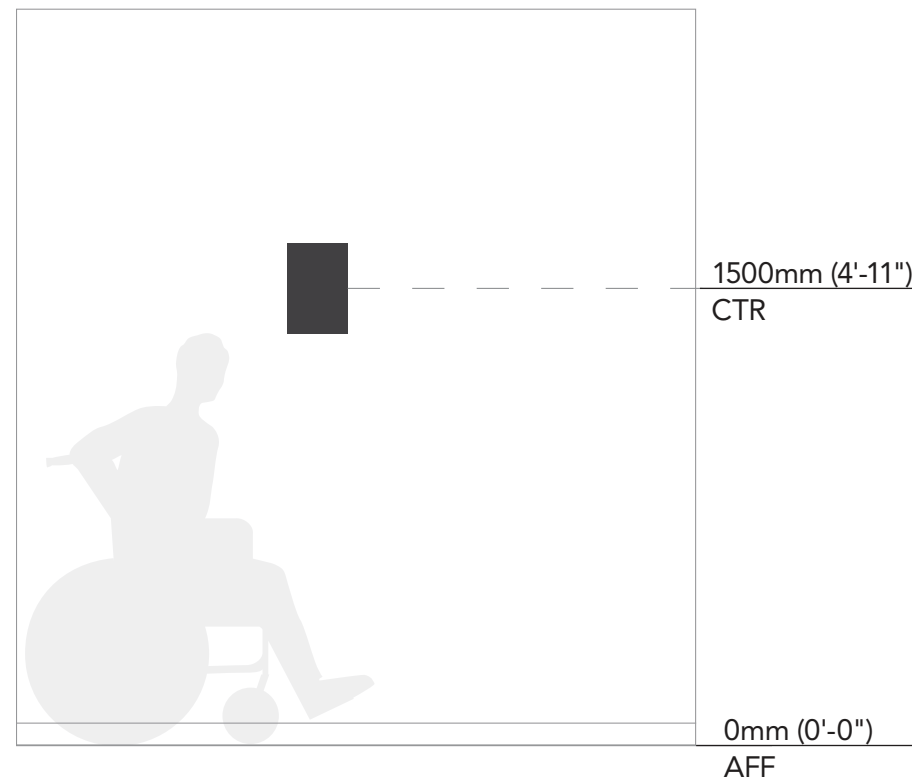

9 Elevation
Scale: 1:25

A.13 Public Safety Amenities

Standard

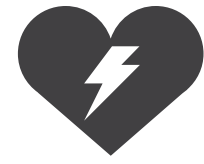
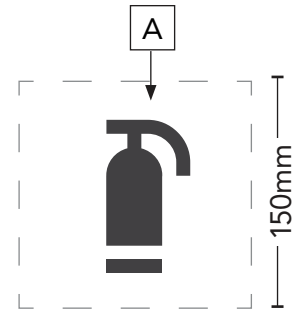

1 Fire Extinguisher
Scale: 1:5

2 Fire Hose
Scale: 1:5

3 AED
Scale: 1:5

4 First Aid
Scale: 1:5

Description

A Die-cut vinyl decal; Charcoal colour (White if needs contrast); Size relative to signage layout in scale

Use

Icon that works as visual support to easily identify any for standard public safety amenities.

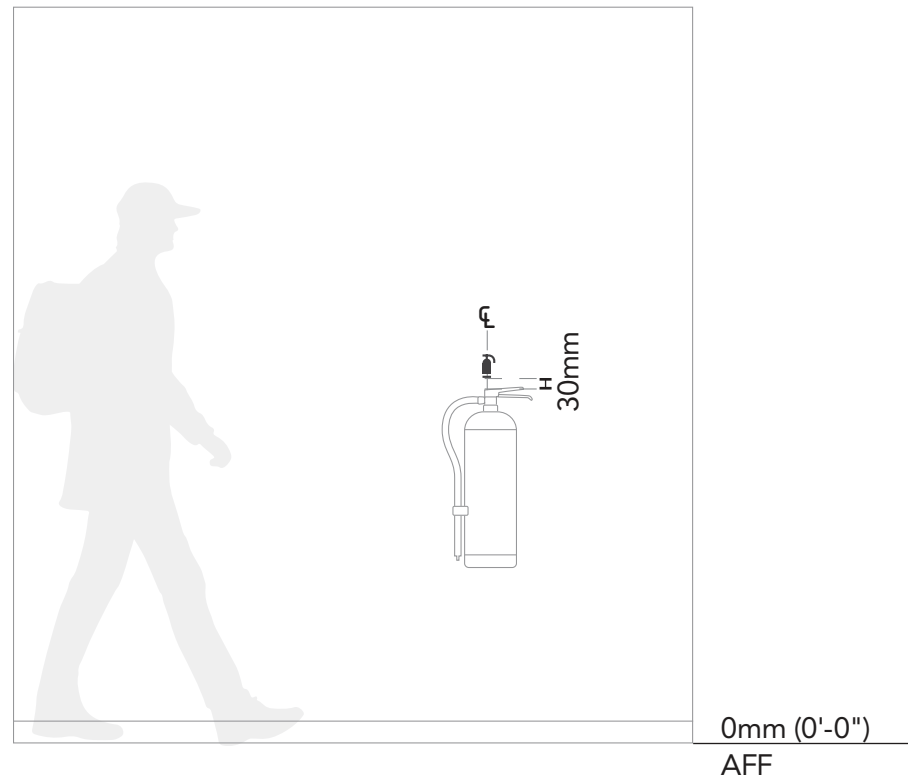

4 Elevation
Scale: 1:25

A.21 Receptacles ID - A

Standard

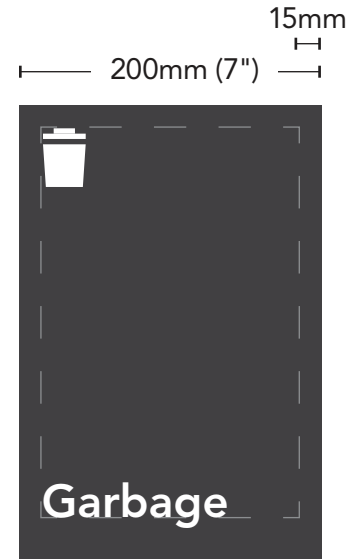

1 Garbage
Scale: 1:5



2 Plastic
Scale: 1:5

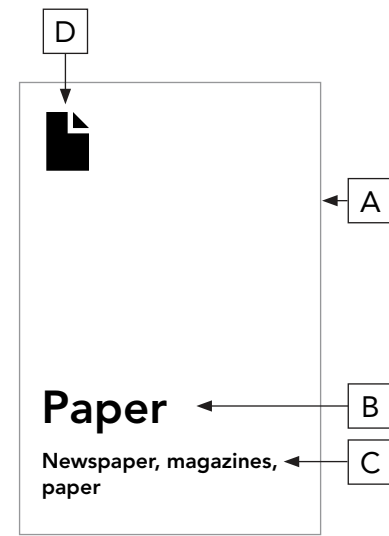

3 Paper
Scale: 1:5



4 Hazardous
Scale: 1:5



5 Compost (Future)
Scale: 1:5

Description

- A** Vinyl sticker or 3mm-thick acrylic panel; Returns to match panel colour; Colour to change per sign; Mounted to surface securely
- B** Avenir LT Std; 85 Heavy; 22.5mm cap-height; Optical kerning; Tracking (0); Left aligned; White or Black
- C** Avenir LT Std; 85 Heavy; 10mm cap-height; Optical kerning; Tracking (0); Left aligned; White or Black
- D** Pictogram; White or Black; Direct print or vinyl; Size relative to signage layout in scale
- E** Poster frame; Black aluminum or similar

Use

Sign for receptacles, where the sign can be used to communicate different types of bins, ie. Garbage, Plastic, Paper, Hazardous; and to encourage MUN's recycling program; perhaps some additional permanent information about the content using pictograms, can be used to add pertinent information.



6 Specialized (Future)
Scale: 1:5

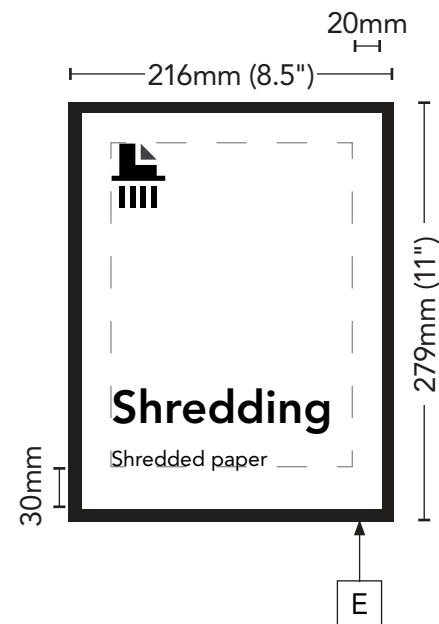

7 Frame
Scale: 1:5



8 Panel Section
Scale: 1:5

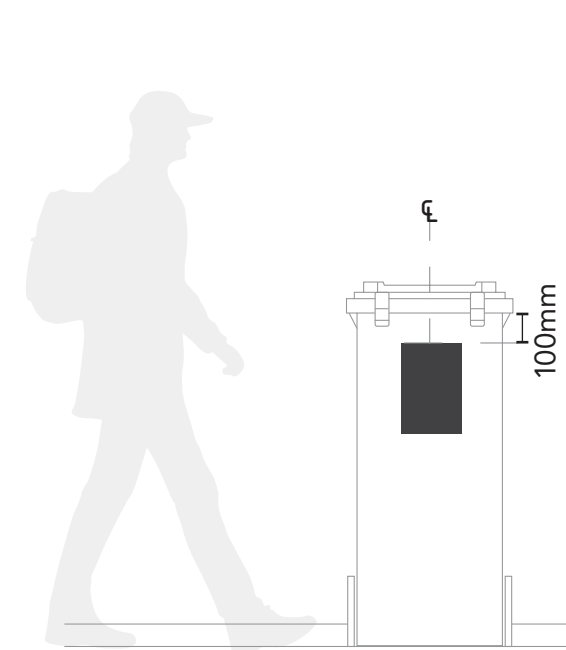

9 Elevation
Scale: 1:25

A.22 Receptacles ID - C

Compact

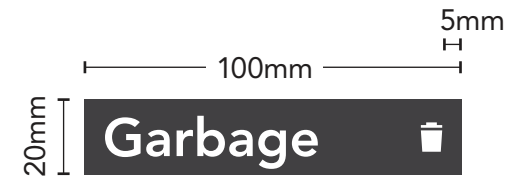

1 Garbage
Scale: 1:2



2 Plastic
Scale: 1:2



3 Paper
Scale: 1:2



4 Hazardous
Scale: 1:2



5 Compost (Future)
Scale: 1:2



6 Specialized (Future)
Scale: 1:2



7 Section
Scale: 1:2

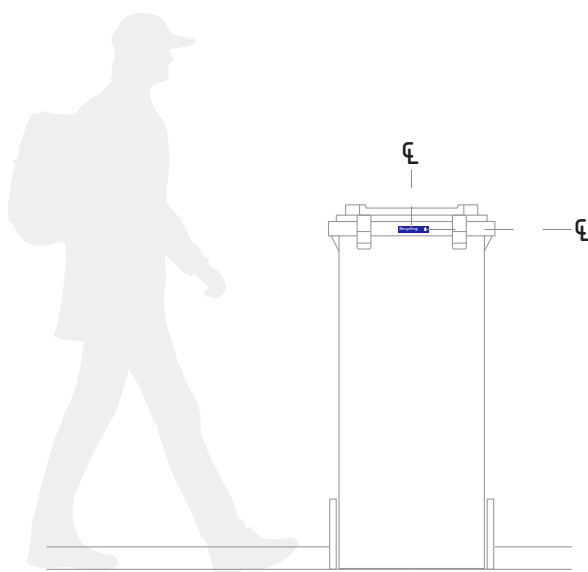

8 Elevation
Scale: 1:25

Description

- A** Vinyl sticker; Colour to change per sign
- B** Avenir LT Std; 85 Heavy; 10mm cap-height; Optical kerning; Tracking (0); Left aligned; White or Black
- C** Pictogram; White or Black; Direct print or vinyl; Size relative to signage layout in scale

Use

Sign for receptacles, where the sign can be used to communicate different types of bins, ie. Garbage, Plastic, Paper, Hazardous; and to encourage MUN's recycling program; perhaps some additional permanent information about the content using pictograms, can be used to add pertinent information.

A.31 Temporary Notices

Standard



1 Layout

Scale: 1:5

Description

- A** White cardstock tabloid paper; Charcoal colour print
- B** Avenir LT Std; 85 Heavy; 18mm cap-height; Optical kerning; Tracking (0); Left aligned; White
- C** Avenir LT Std; 65 Medium; 7mm cap-height; Optical kerning; Tracking (0); Left aligned; White
- D** Pictogram; White and/or PMS 185; Direct print; Size relative to signage layout in scale
- E** Poster frame; Black aluminum or similar; Required certificates (future)

Use

Sign for temporary notices, where the sign can be used to communicate different types of messages; perhaps some additional information about the content using pictograms can be used to add pertinent information. These are to be non-permanent for ease of fabrication and to easily update signage for end users.



2 Frame

Scale: 1:5

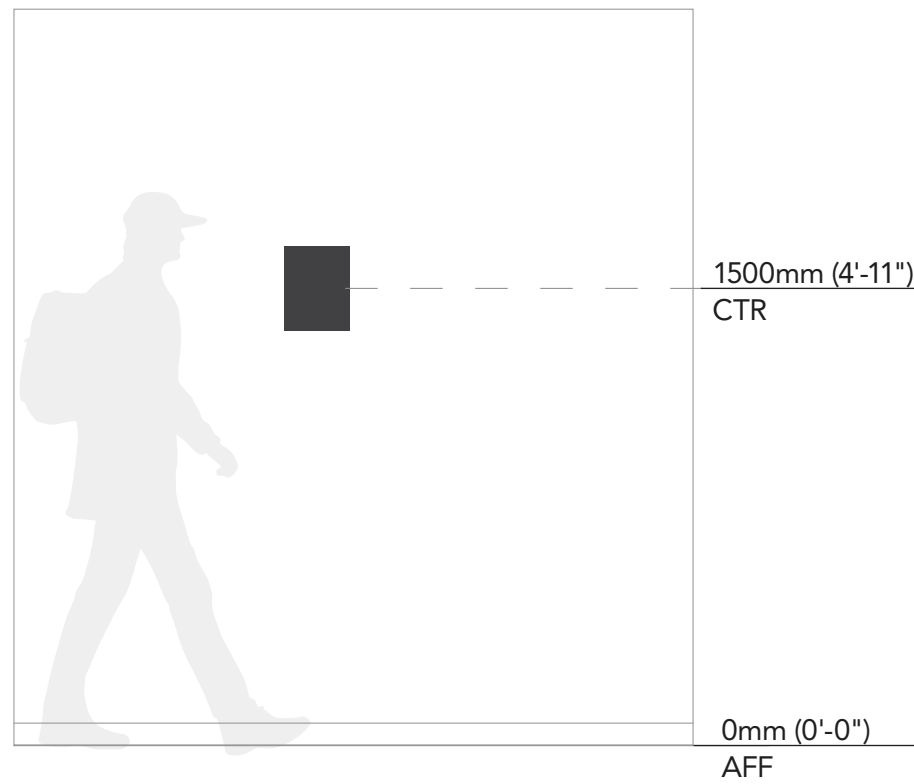

3 Elevation

Scale: 1:25

C.32 Framing

Standard

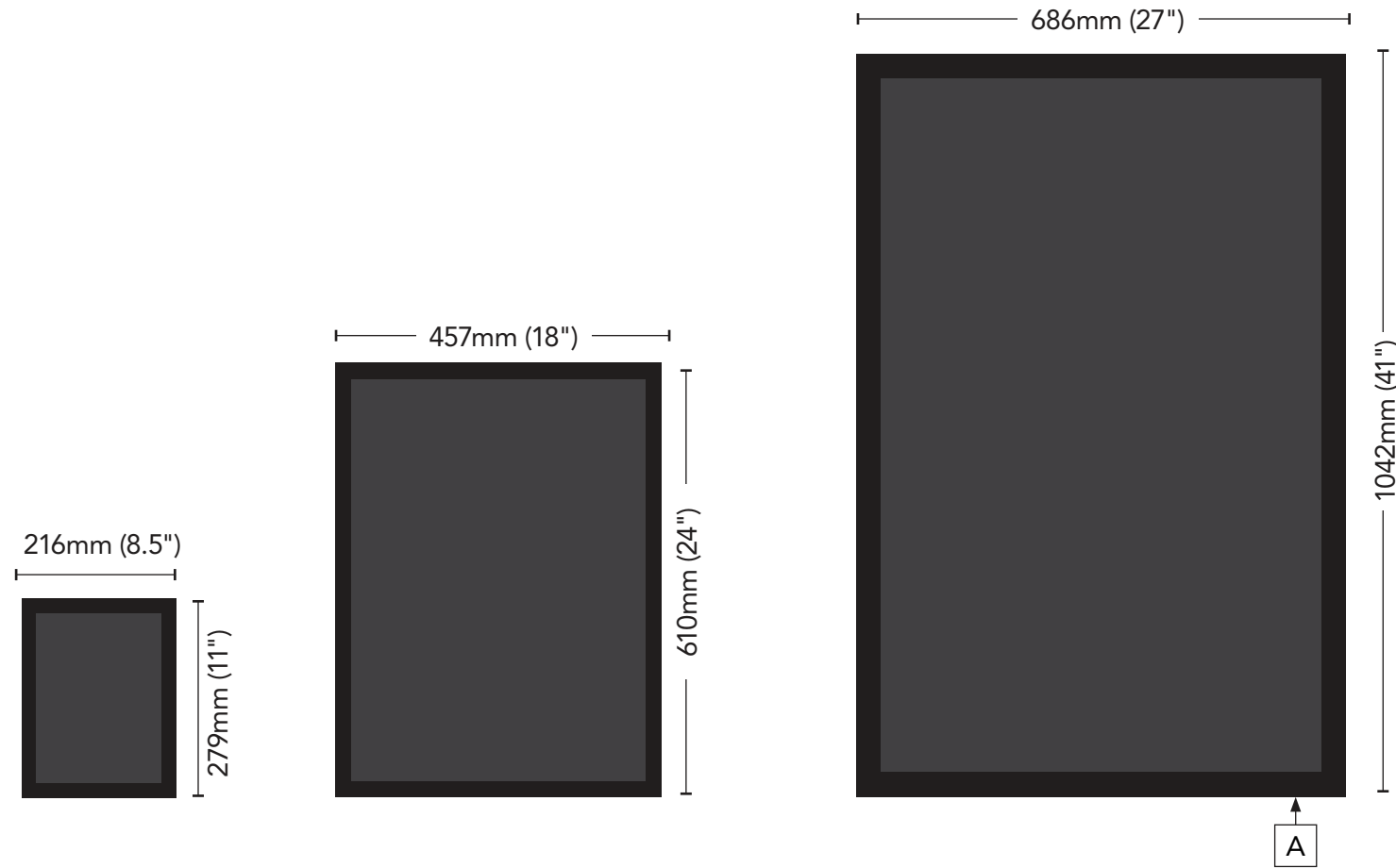

Description

A Poster frame; Black aluminum or similar.

Potential specification https://www.uline.ca/BL_1594/Snap-Edge-Frame-Signs?keywords=frames

Use

Frames can be used to temporarily display signs or to allow for an interchangeable solution when a sign has to be updated and communicate different types of messages, giving the ability to easily change signage for fabricators, as well as end users.

1

Frames

Scale: 1:10

B.01 Entrance ID

Compact

Robert G. Reid III Theatre | 25mm

1 Layout: One Line
Scale: 1:5



2 Layout: Two Lines
Scale: 1:5

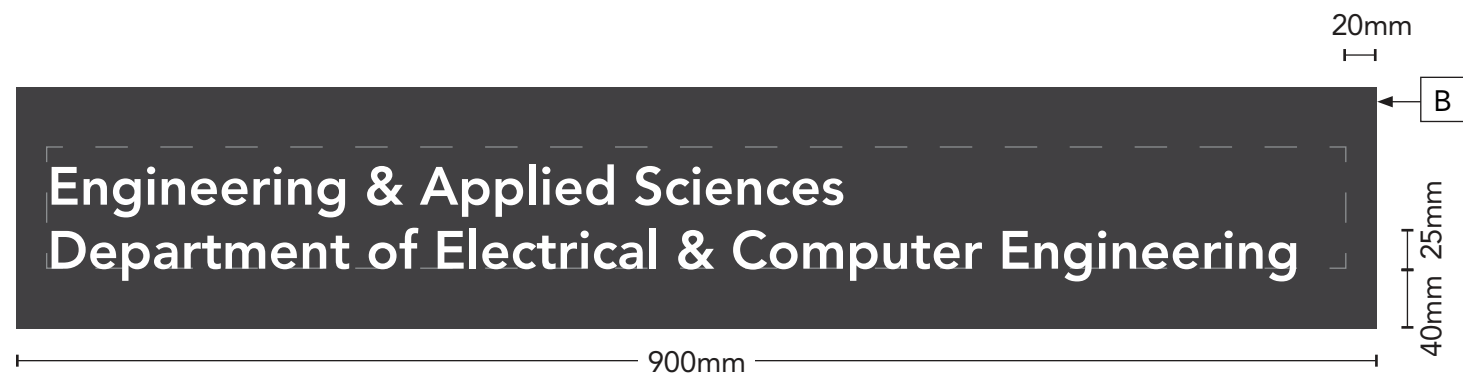

4 Layout: Panel
Scale: 1:5

Introduction

Signage

Wayfinding

Branding

24

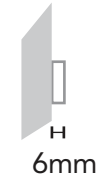

3 Section: Letter
Scale: 1:5

Description

- A** Vinyl or 6mm-deep acrylic; Avenir LT Std; 85 Heavy; 25mm cap-height; Left aligned; white (Charcoal if needs contrast); Left aligned; Mounted to wall surface securely; Flush to wall surface; Prioritize location above doors; Installed vertically if space above door is not adequate
- B** Vinyl sticker or 3mm-thick acrylic panel; Colour to change per sign; Returns to match panel colour; Mounted to wall surface securely

Use

Entrance identifications where the sign can be used to recognize the entry to a specific space, department or area.

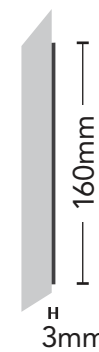

5 Section: Panel
Scale: 1:5

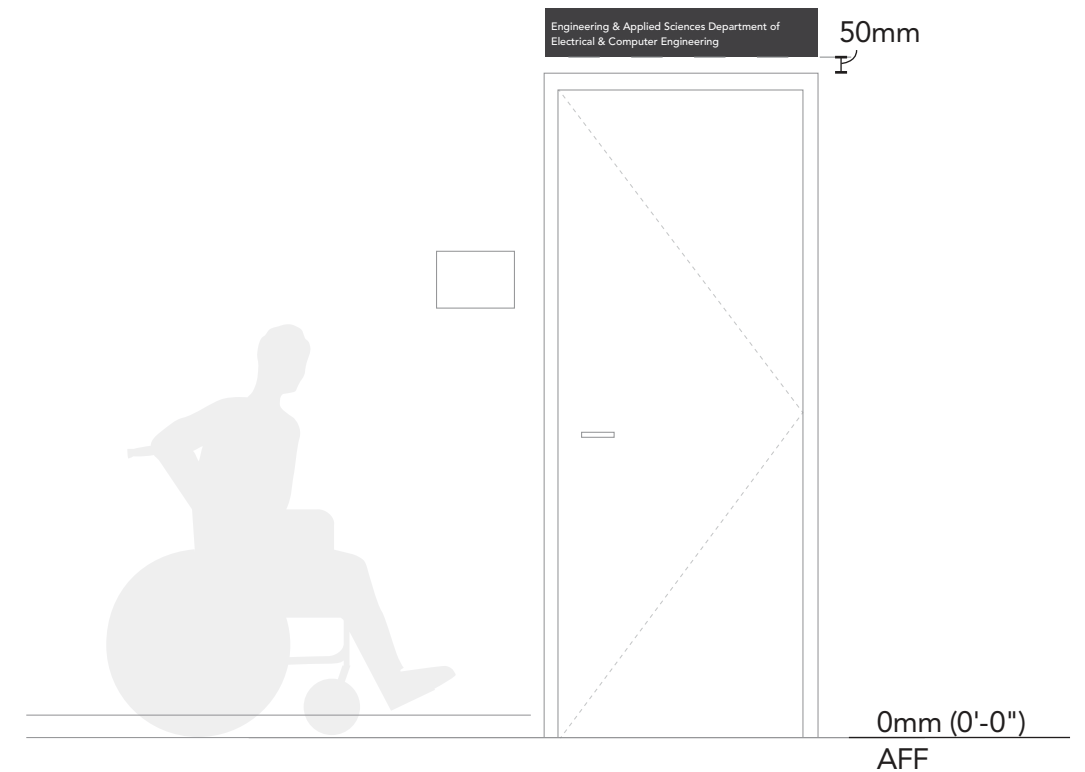

6 Elevation
Scale: 1:25

B.02 Entrance ID

Standard



1 **Layout: One Line**
Scale: 1:5



2 **Layout: Two Lines**
Scale: 1:5



4 **Layout: Panel**
Scale: 1:5

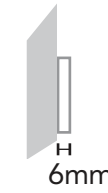

3 **Section: Letter**
Scale: 1:5

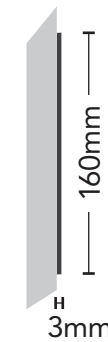

5 **Section: Panel**
Scale: 1:5



6 **Elevation**
Scale: 1:25

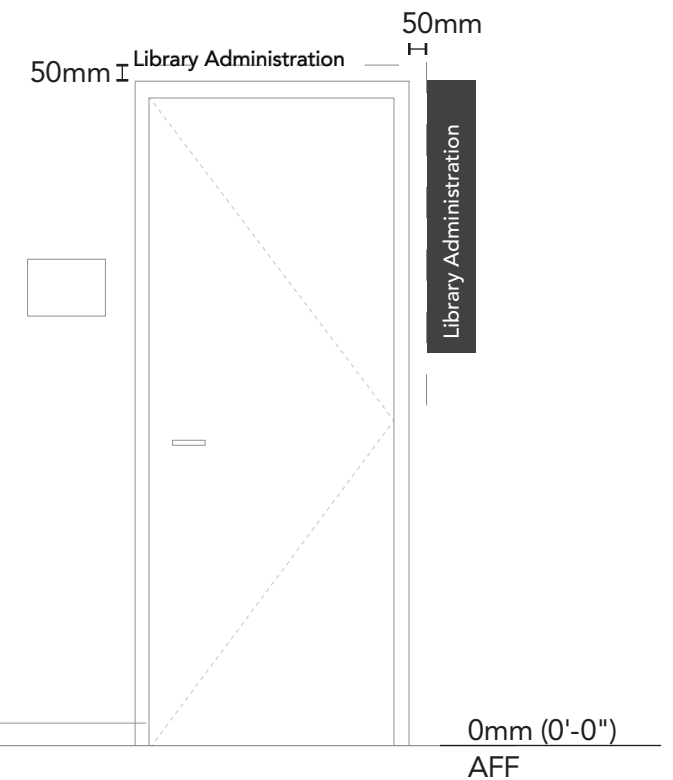

Description

- A** Vinyl or 6mm-deep acrylic; Avenir LT Std; 65 Medium; 50mm cap-height; Left aligned; White (Charcoal if needs contrast); Left aligned; Mounted to wall surface securely; Flush to wall surface; Prioritize location above doors; Installed vertically if space above door is not adequate
- B** Vinyl sticker or 3mm-thick acrylic panel; Colour to change per sign; Returns to match panel colour; Mounted to wall surface securely

Use

Entrance identifications where the sign can be used to recognize the entry to a specific space, department or area.

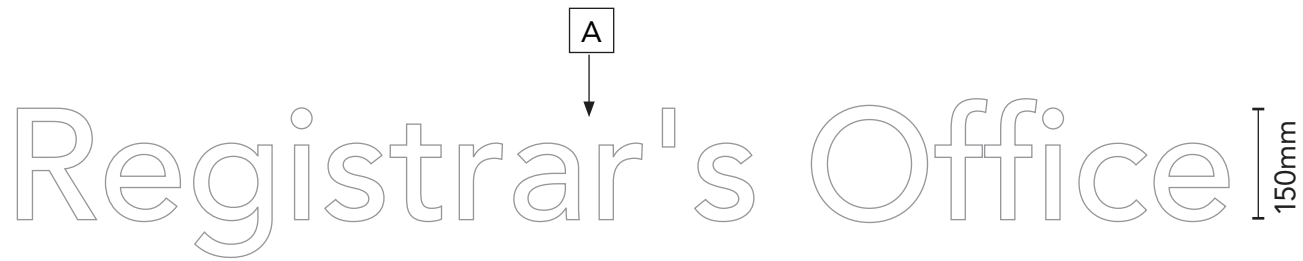

1 Layout
Scale: 1:10

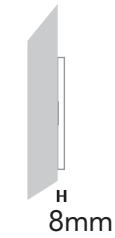

2 Section: Letter
Scale: 1:10



3 Layout: Panel
Scale: 1:10



4 Section: Panel
Scale: 1:10

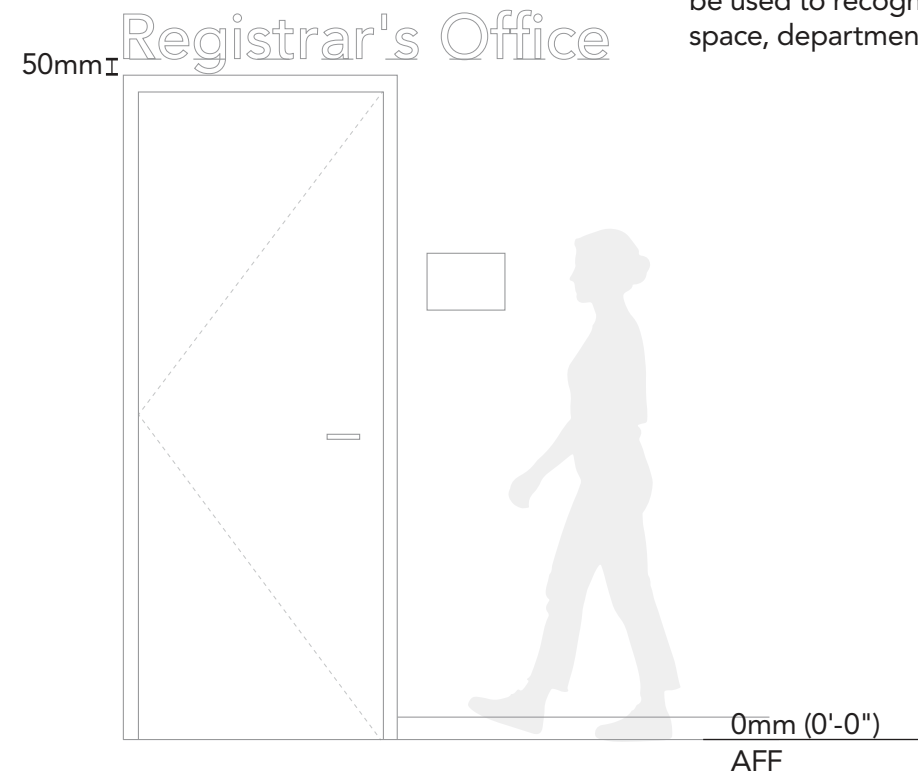

5 Elevation
Scale: 1:25

Description

- A Vinyl, 8mm-deep acrylic, or 50mm-deep illuminated channel letters (future); Avenir LT Std; 65 Medium; 150mm cap-height; Left aligned; White (Charcoal if needs contrast); Mounted to wall surface securely; Flush to wall surface; Prioritize location above doors; Installed vertically if space above door is not adequate
- B Vinyl Sticker or 3mm-thick acrylic panel; Returns to match panel colour; Colour to change per sign; Mounted to wall surface securely
- C Margin to remain at 80mm from the cap-height and length of message; Panel to adjust with message

Use

Entrance identifications where the sign can be used to recognize the entry to a specific space, department or area.

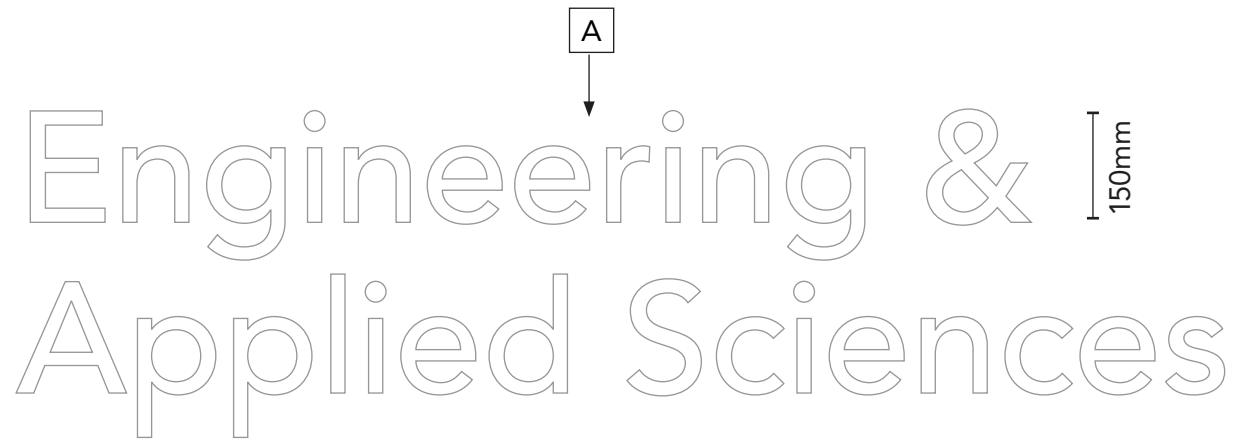

1 **Layout**
Scale: 1:10

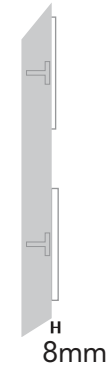

2 **Section: Letter**
Scale: 1:10

Description

- A** Vinyl, 8mm-deep acrylic, or 50mm-deep illuminated channel letters (future); Avenir LT Std; 65 Medium; 150mm cap-height; Left aligned; White (Charcoal if needs contrast); Mounted to wall surface securely; Flush to wall surface; Prioritize location above doors; Installed vertically if space above door is not adequate
- B** Vinyl Sticker or 3mm-thick acrylic panel; Returns to match panel colour; Colour to change per sign; Mounted to wall surface securely
- C** Margin to remain at 80mm from the cap-height and length of message; Panel to adjust with message

Use

Entrance identifications where the sign can be used to recognize the entry to a specific space, department or area.



3 **Layout: Panel**
Scale: 1:10



4 **Section: Panel**
Scale: 1:10

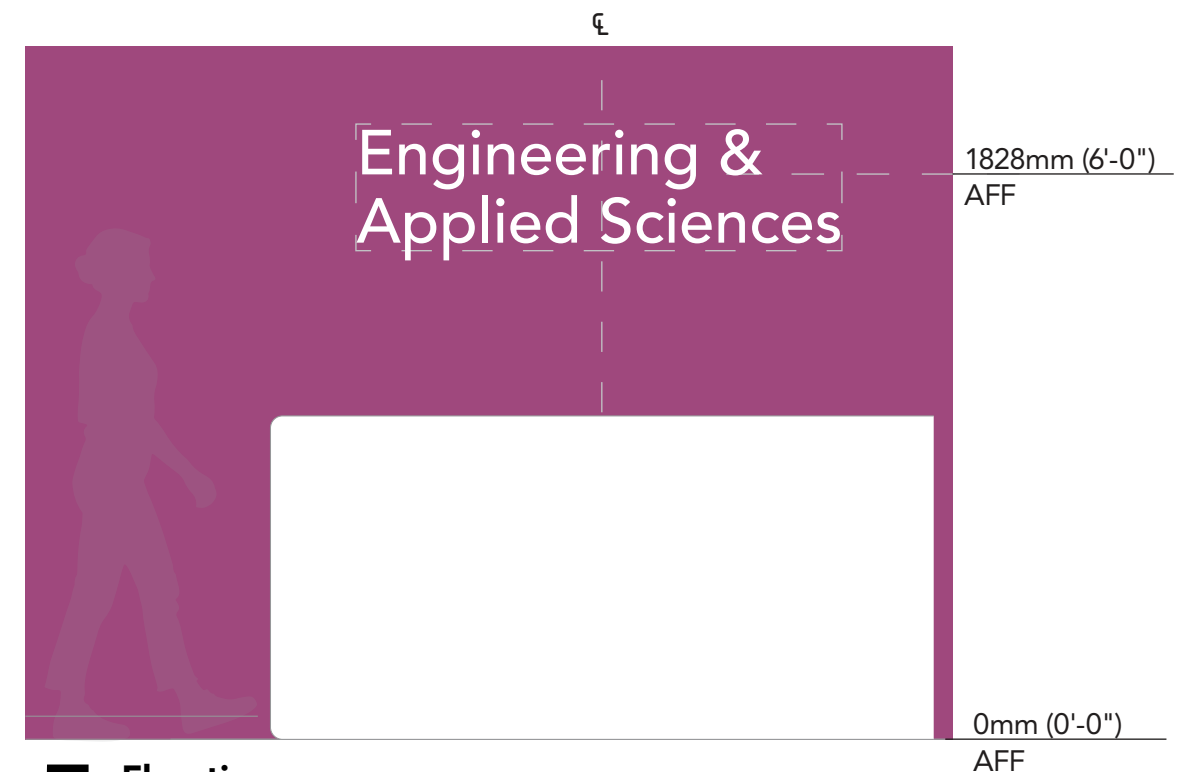

5 **Elevation**
Scale: 1:25

B.11 Floor Level

Compact

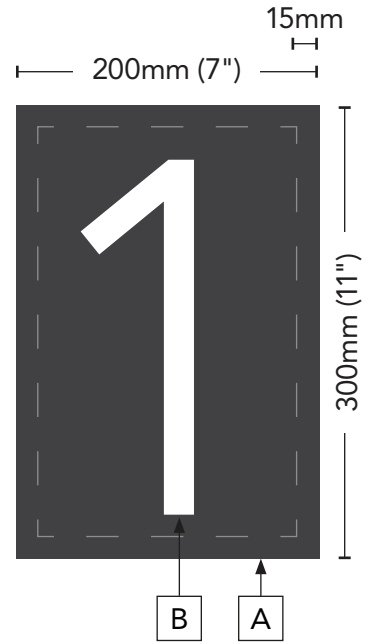

1 Vinyl Layout
Scale: 1:5

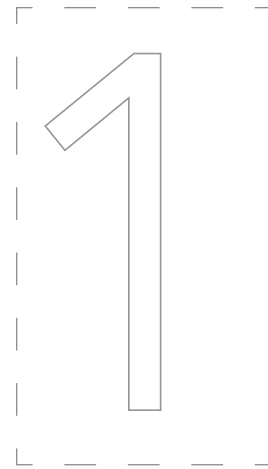

2 Vinyl Layout
Scale: 1:5

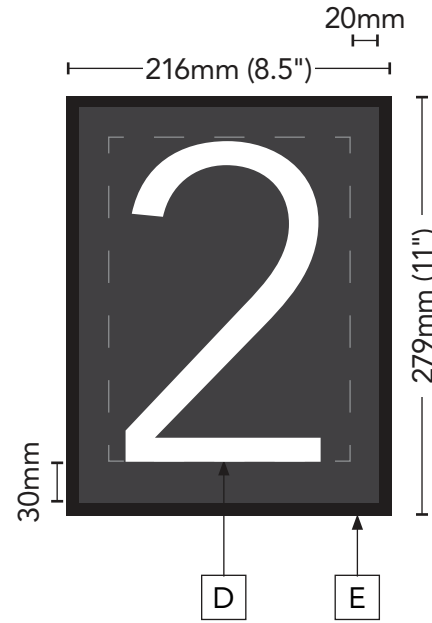
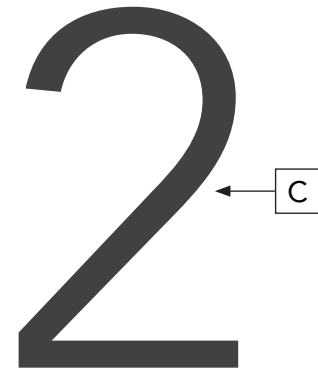

3 Frame
Scale: 1:5

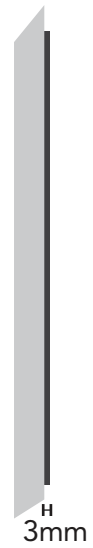

4 Section
Scale: 1:5

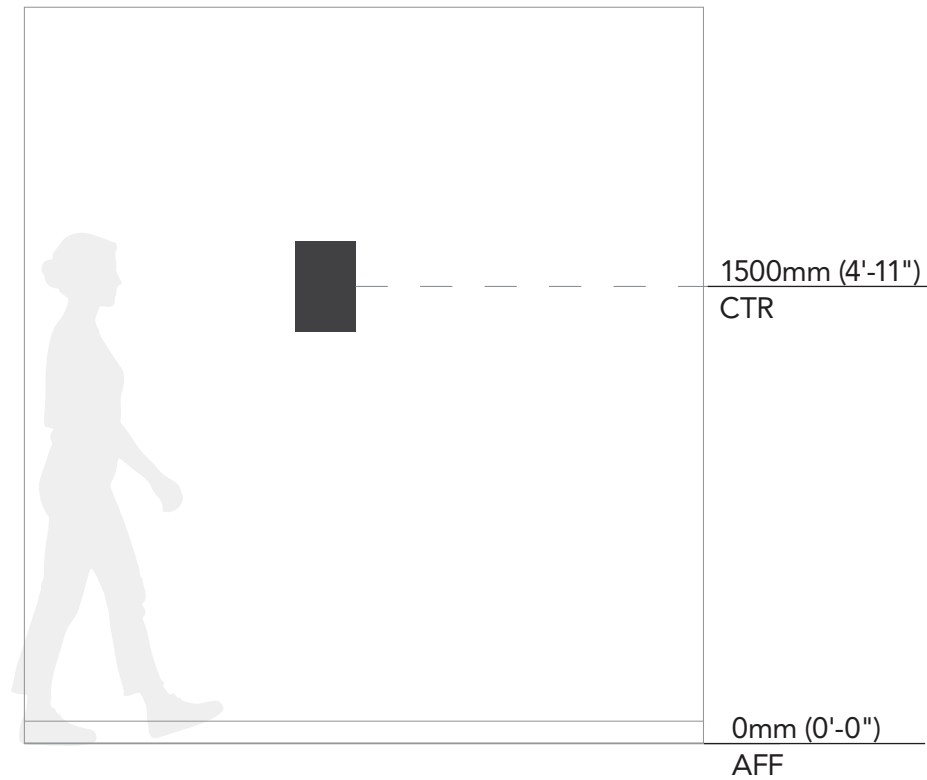

5 Elevation
Scale: 1:25

Description

- A** 3mm-thick acrylic panel; Charcoal colour; Returns to match panel colour; Mounted to wall surface securely
- B** Avenir LT Std; 35 Light; 234mm cap-height; Optical kerning; Tracking (0); White; Direct print or vinyl
- C** Avenir LT Std; 35 Light 234mm cap-height; Optical kerning; Tracking (0); White (Charcoal if needs contrast); Die-cut vinyl
- D** Avenir LT Std; 35 Light; 210mm cap-height; Optical kerning; Tracking (0); Charcoal
- E** Poster frame; Black aluminum or similar

Use

Floor number signs, where the sign can be used to communicate the floor you are located on; give users the confidence to navigate spaces intuitively.

B.12 Floor Level

Standard

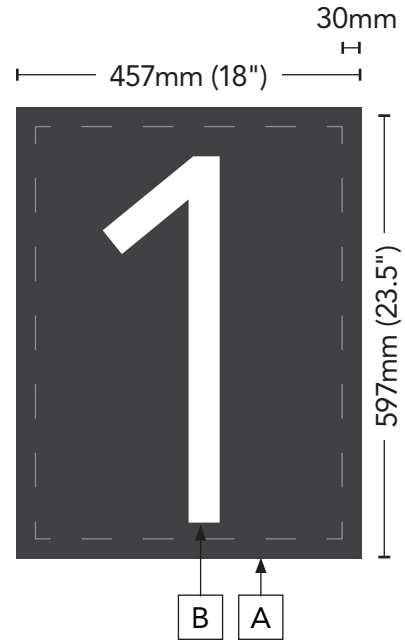

1 Layout
Scale: 1:10

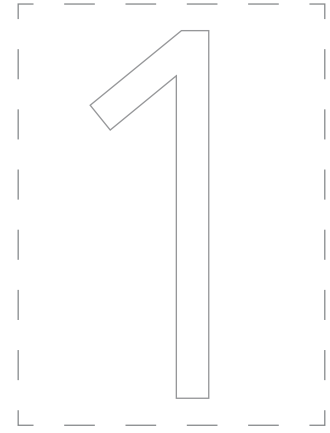

2 Layout: Number
Scale: 1:10

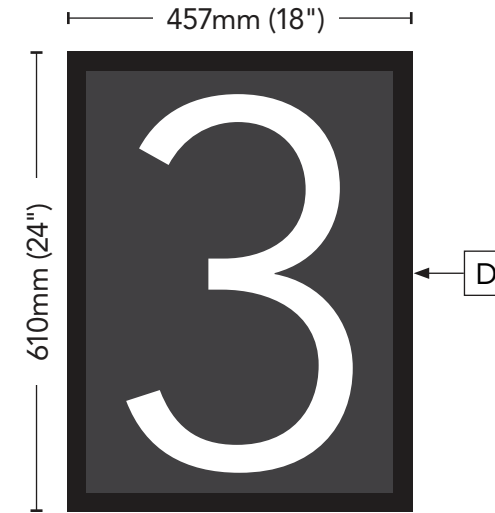
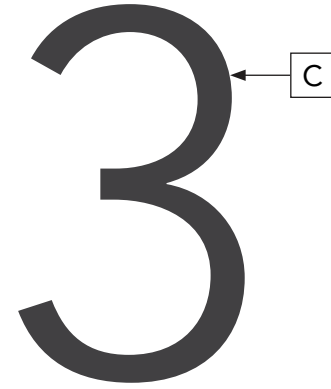

3 Frame
Scale: 1:10

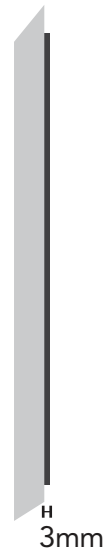

4 Section
Scale: 1:10

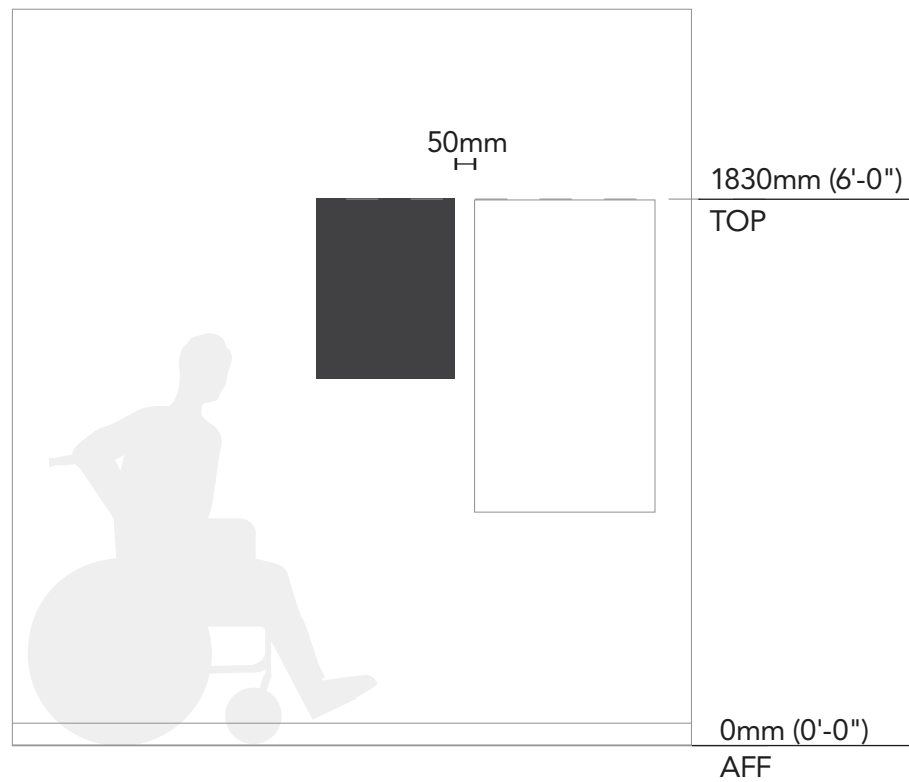

5 Elevation
Scale: 1:25

Description

- A** 3mm-thick acrylic panel; Charcoal colour; Returns to match panel colour; Mounted to wall surface securely
- B** Avenir LT Std; 35 Light; 500mm cap-height; Optical kerning; Tracking (0); White; Direct print or vinyl
- C** Avenir LT Std; 35 Light; 500mm cap-height; Optical kerning; Tracking (0); White (Charcoal if needs contrast); Die-cut vinyl
- D** Poster frame; Black aluminum or similar

Use

Floor number signs, where the sign can be used to communicate the floor you are located on; give users the confidence to navigate spaces intuitively.

B.20 Blade Signage

Standard

13mm 20mm 20mm
213mm (8")

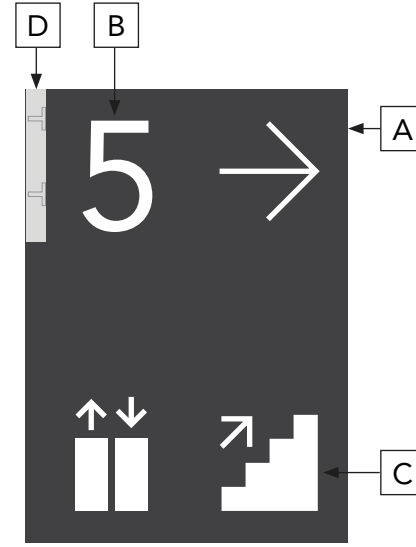
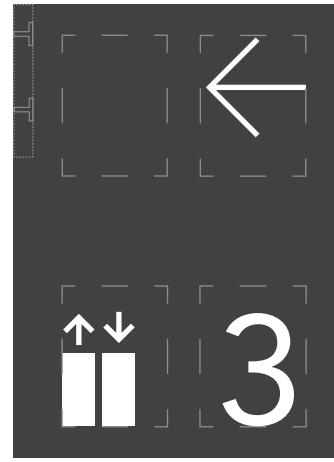
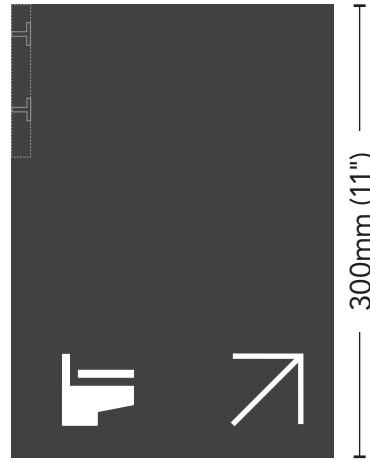
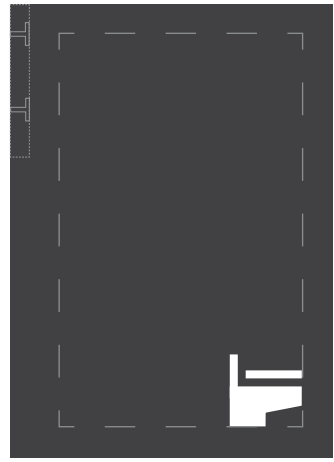

3mm
H



1 Layout

Scale: 1:5

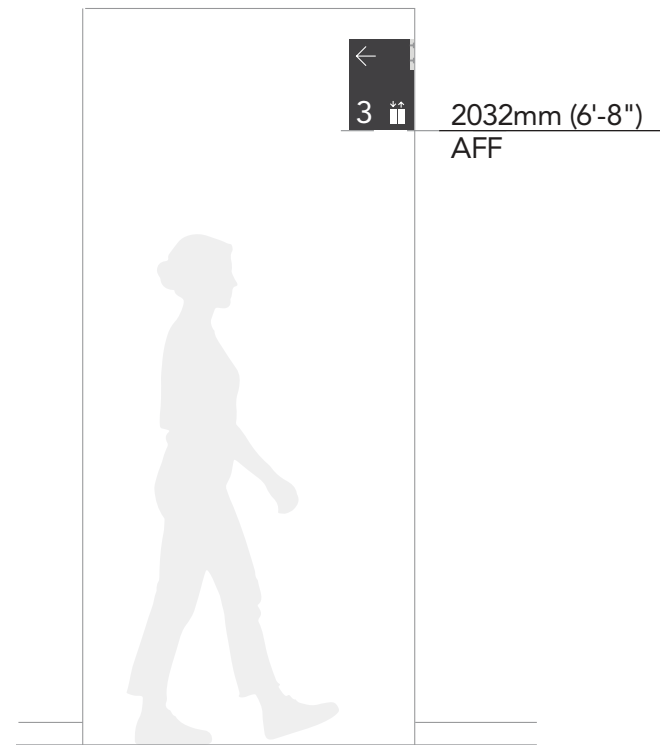

3 Elevation

Scale: 1:25

2 Section

Scale: 1:5

Description

- A** 3mm-thick acrylic panel; Charcoal colour; Returns to match panel colour; Mounted to wall surface securely
- B** Avenir LT Std; 55 Roman; 75mm cap-height; Optical kerning; Tracking (0); Left aligned; White; Direct print or vinyl
- C** Pictogram; White; Direct print or vinyl; Prioritize arrows opposite to the wall side; Prioritize icons to the bottom first, then opposite to the wall side; Size relative to signage layout in scale
- D** Fastened to wall with screws at top and bottom of sign or similar; Fastenings to be concealed; To match panel colour

Use

Blade signs, where the sign can be used to communicate different types of spaces, ie. Elevators, Washrooms; give users the confidence to navigate spaces intuitively.

B.21 Directional

Standard

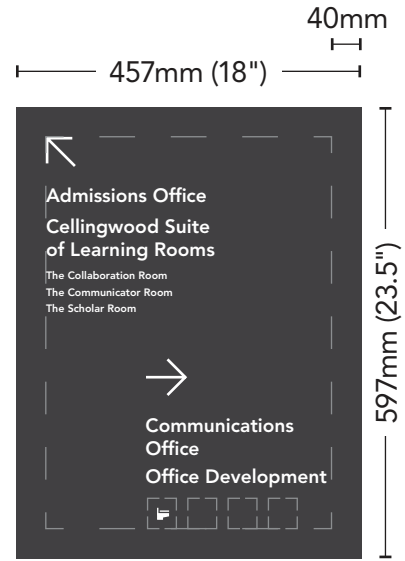

1 Layout
Scale: 1:10

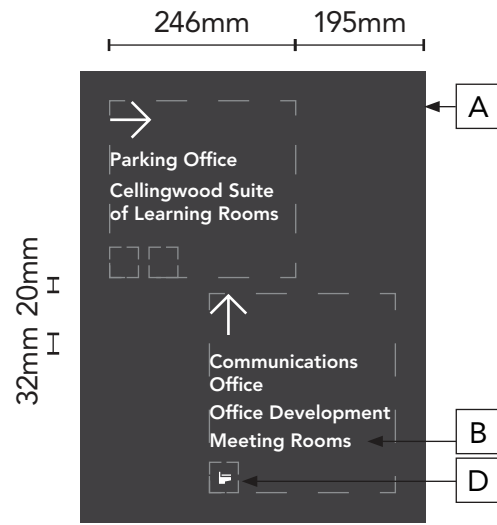

2 Frame
Scale: 1:10

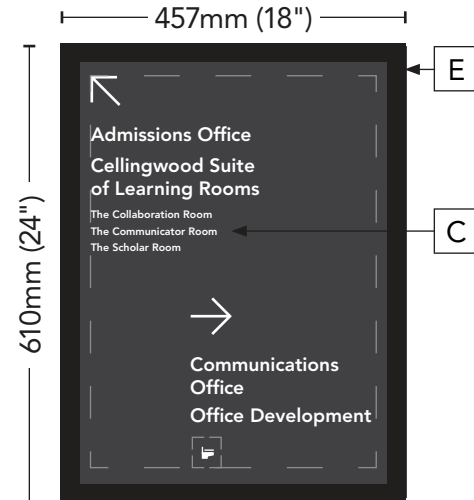

3 Section
Scale: 1:10

Description

- A** 3mm-thick acrylic panel; Charcoal colour; Returns to match panel colour; Mounted to wall surface securely
- B** Avenir LT Std; 85 Heavy; 18mm cap-height; Optical kerning; Tracking (0); Left aligned; White; Direct print or vinyl
- C** Avenir LT Std; 85 Heavy; 10mm cap-height; Optical kerning; Tracking (0); Leading 6.5mm; Left aligned; White; Direct print or vinyl
- D** Pictogram; White; Direct print or vinyl
- E** Poster frame; Black aluminum or similar

Use

Directional signs, where the sign can be used to communicate different types of spaces, departments or areas, give users the confidence to navigate spaces intuitively.

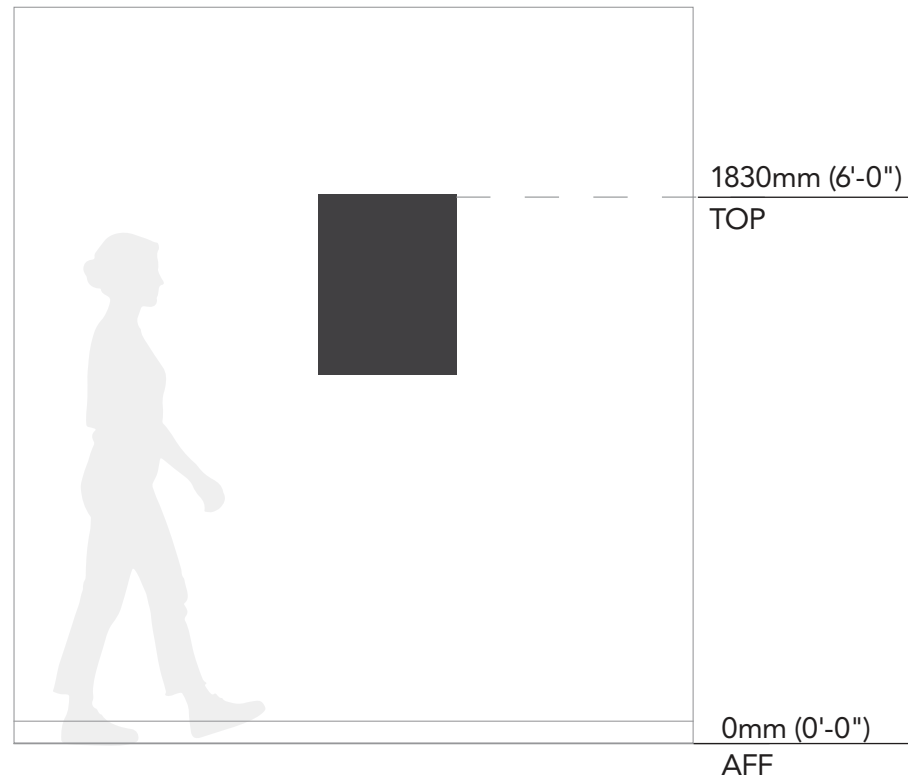

4 Elevation
Scale: 1:25

B.22 Directional

Compact

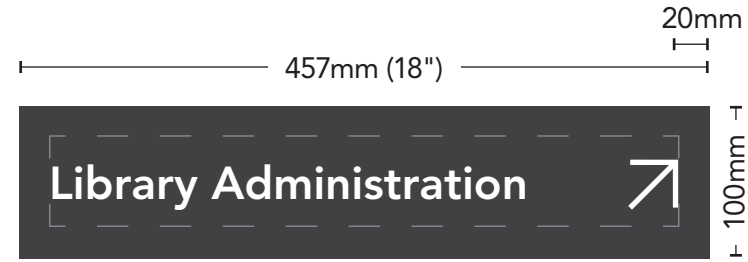

1 Layout: One Line
Scale: 1:5



2 Layout: Two Line
Scale: 1:5

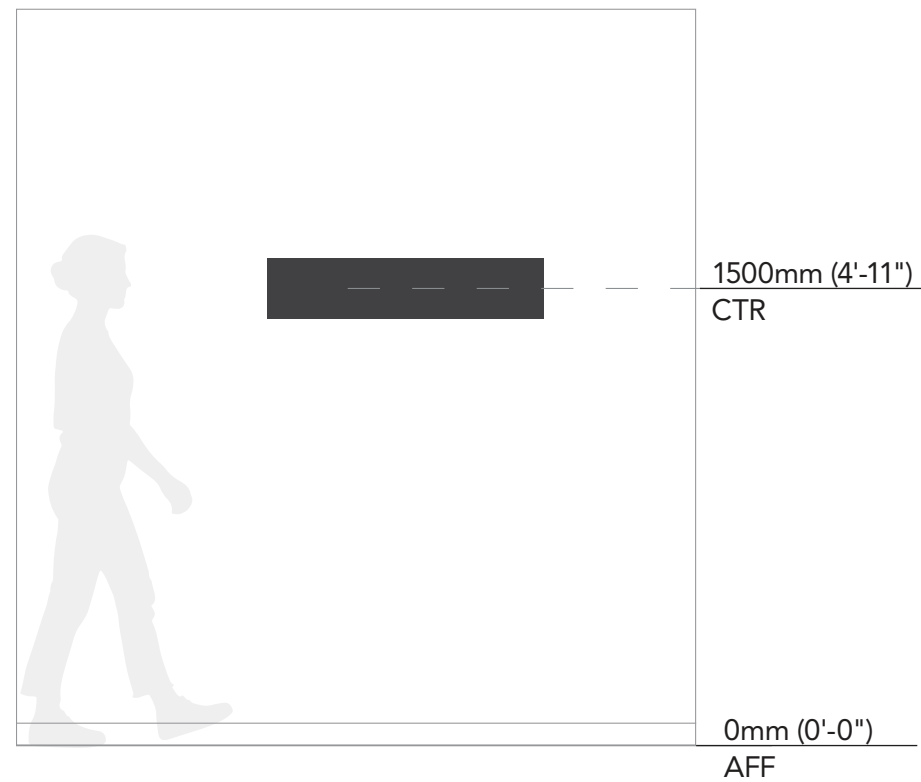

5 Elevation
Scale: 1:25

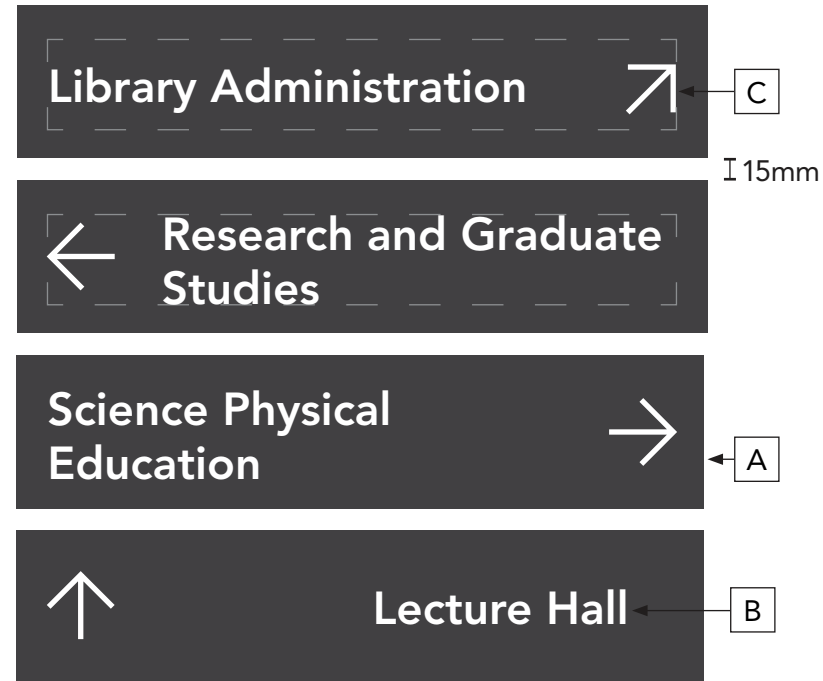

3 Layout: Stacked
Scale: 1:5

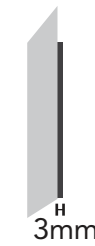

4 Section
Scale: 1:5

Description

- A** 3mm-thick acrylic panel; Charcoal colour; or MUNnel colours; Returns to match panel colour; Mounted to wall surface securely
- B** Avenir LT Std; 85 Heavy; 22.5mm cap-height; Optical kerning; Tracking (0); Left aligned; white; Direct print or vinyl
- C** Arrows; White; Direct print or vinyl; Size relative to signage layout in scale

Use

Directional signs, where the sign can be used to communicate different types of spaces, departments or areas, give users the confidence to navigate spaces intuitively.

B.23 Directional

MUNnel

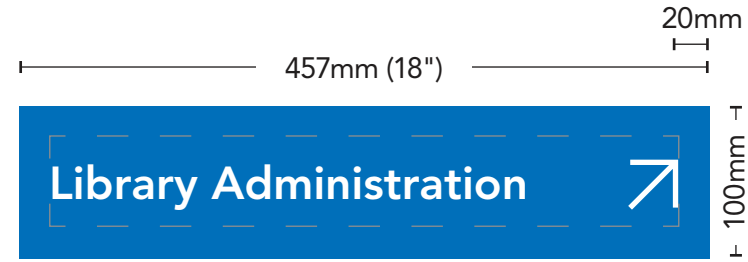

1 Layout: One Line
Scale: 1:5



2 Layout: Two Line
Scale: 1:5

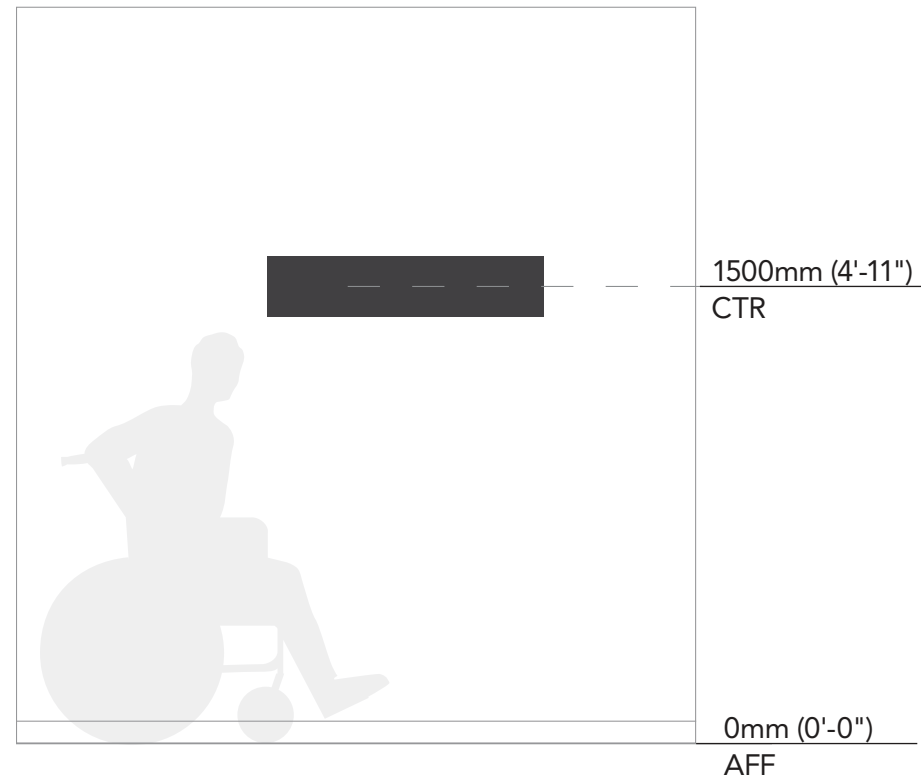

5 Elevation
Scale: 1:25

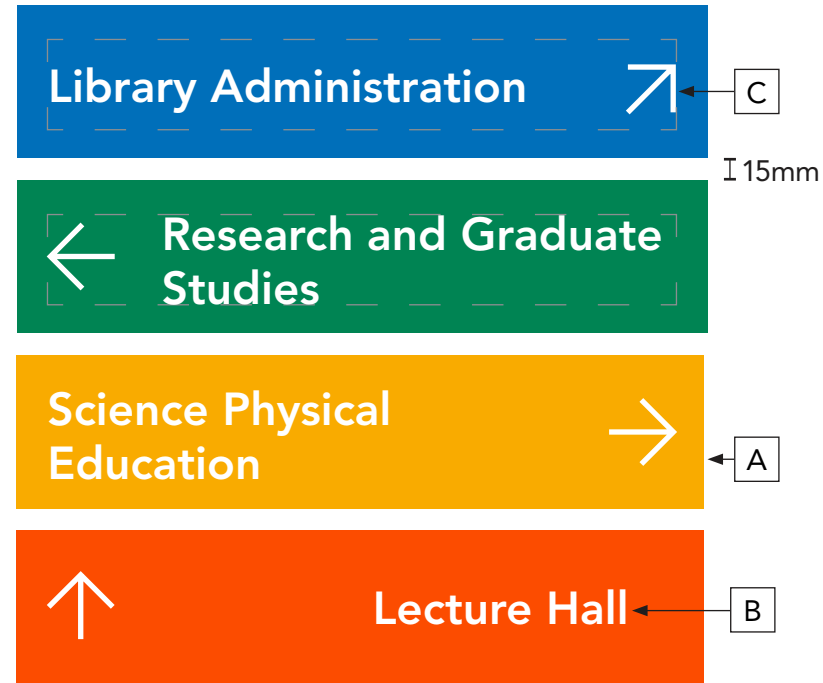

3 Layout: MUNnel
Scale: 1:5

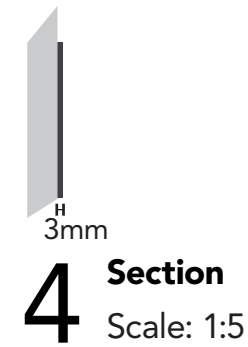

Description

- A** 3mm-thick acrylic panel; Charcoal colour; or MUNnel colours; Returns to match panel colour; Mounted to wall surface securely
- B** Avenir LT Std; 85 Heavy; 22.5mm cap-height; Optical kerning; Tracking (0); Left aligned; white; Direct print or vinyl
- C** Arrows; White; Direct print or vinyl; Size relative to signage layout in scale

Use

Directional signs, where the sign can be used to communicate different types of spaces, departments or areas, give users the confidence to navigate spaces intuitively.

B.31 Building Directories

Standard

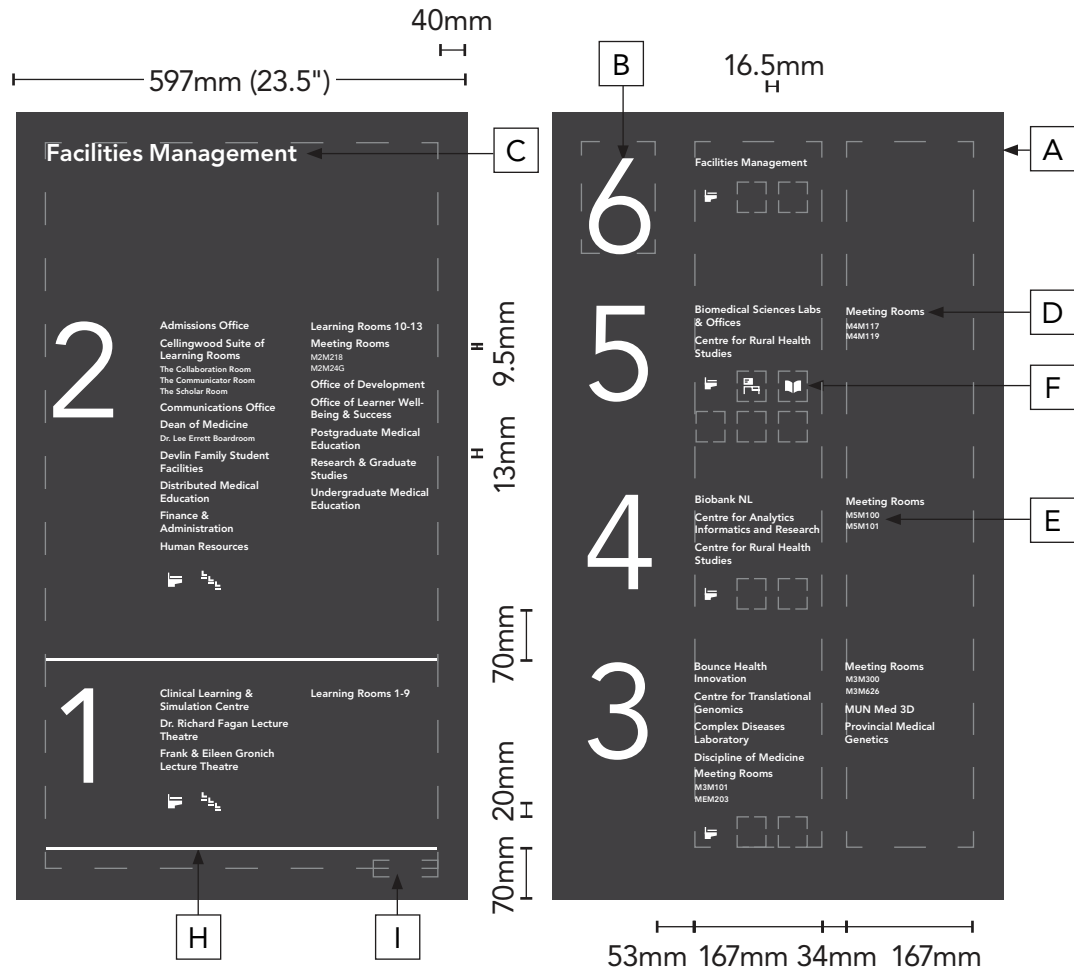

1 Layout
Scale: 1:10



2 Frame
Scale: 1:10

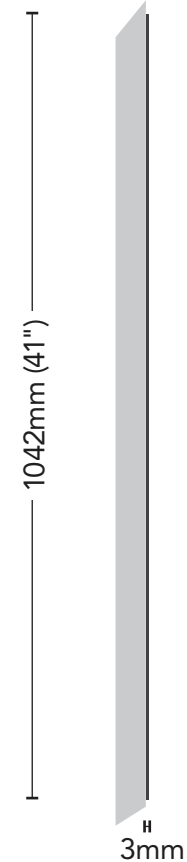

3 Section
Scale: 1:10

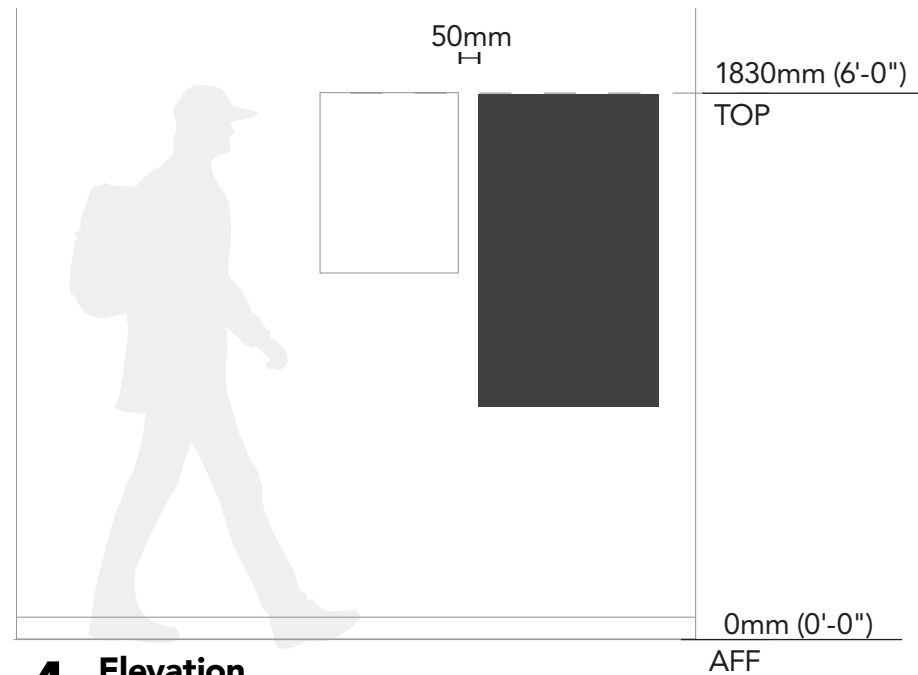

4 Elevation
Scale: 1:25

Description

- A** 3mm-thick acrylic panel; Charcoal colour; Returns to match panel colour; Mounted to wall surface securely
- B** Avenir LT Std; 45 Book; 108mm cap-height; Optical kerning; Tracking (0); Left aligned; White; Direct print or vinyl
- C** Avenir LT Std; 85 Heavy; 22.5mm cap-height; Optical kerning; tracking (0); Left aligned; White; Direct print or vinyl
- D** Avenir LT Std; 85 Heavy; 10mm cap-height; Optical kerning; Tracking (0); Leading 6.5m; Left aligned; White; Direct print or vinyl
- E** Avenir LT Std; 85 Heavy; 7.5mm cap-height; Optical kerning; Tracking (0); Leading 6.5mm; Left aligned; White; Direct print or vinyl
- F** Pictogram; White; Direct print or vinyl; Size relative to signage layout in scale
- G** Poster frame; Black aluminum or similar
- H** Line indicating floor location; White; Direct print or vinyl
- I** Logo; White; Direct print or vinyl (future)

Use

Directories, where the sign can be used to communicate different types of spaces, departments or areas located in each floor, give users the confidence to navigate spaces intuitively.

B.32 Floor Directories

Standard

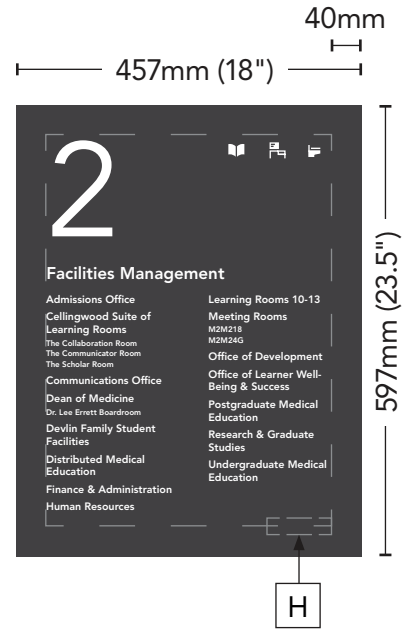

1 Layout
Scale: 1:10

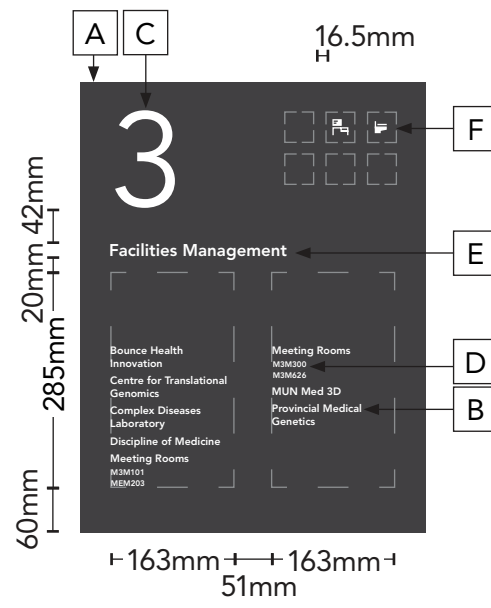

2 Frame
Scale: 1:10

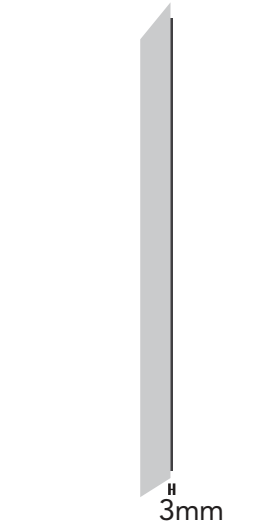

3 Section
Scale: 1:10

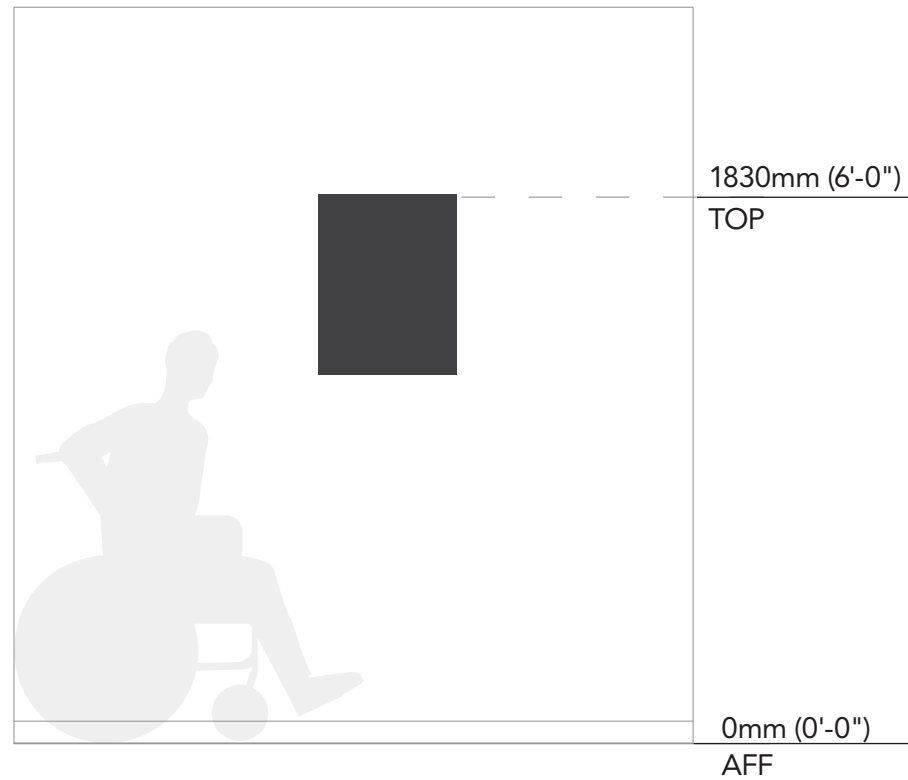

4 Elevation
Scale: 1:25

Description

- A** 3mm-thick acrylic panel; Charcoal colour; Returns to match panel colour; Mounted to wall surface securely
- B** Avenir LT Std; 85 Heavy; 10mm cap-height; Optical kerning; Tracking (0); Leading 6.5mm; Left aligned; White; Direct print or vinyl
- C** Avenir LT Std; 45 Book; 127mm cap-height; Optical kerning; Tracking (0); Left aligned; White; Direct print or vinyl
- D** Avenir LT Std; 85 Heavy; 7.5mm cap-height; Optical kerning; Tracking (0); Leading 6.5mm; Left aligned; White; Direct print or vinyl
- E** Avenir LT Std; 85 Heavy; 16mm cap-height; Optical kerning; Tracking (0); Leading 6.5mm; Left aligned; White; Direct print or vinyl
- F** Pictograms; White; Direct print or vinyl; Size relative to signage layout in scale
- G** Poster frame; Black aluminum or similar; Insert to be printed on white cardstock
- H** Logo; White; Direct print or vinyl (future)

Use

Directories, where the sign can be used to communicate different types of spaces, departments or areas located on each floor, give users the confidence to navigate spaces intuitively.

B.41 Maps

Standard

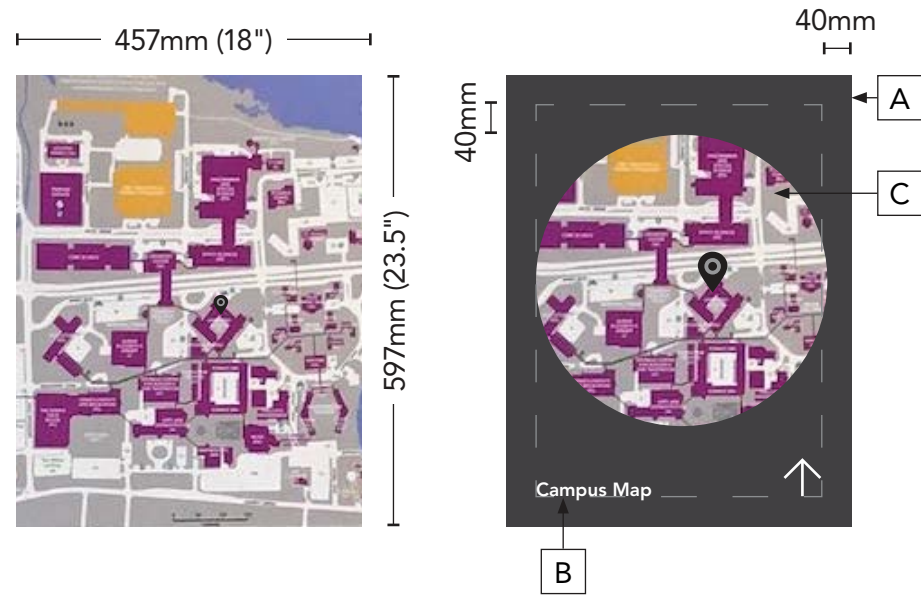

1 Layout
Scale: 1:10

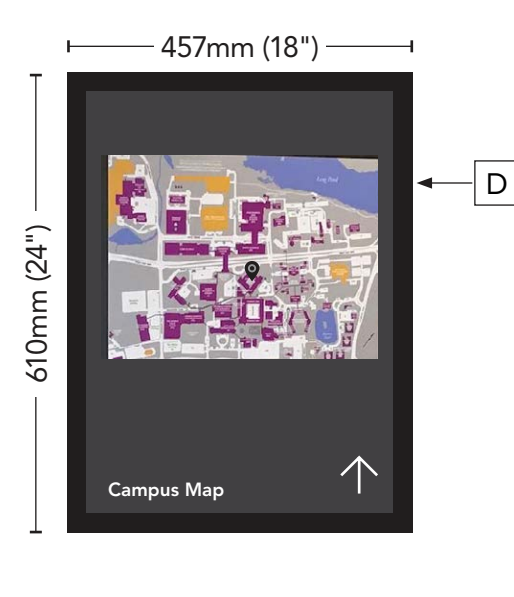

2 Frame
Scale: 1:10

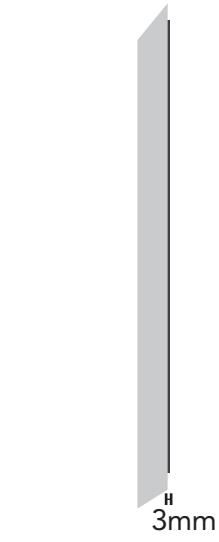

3 Section
Scale: 1:10

Description

- A** 3mm-thick acrylic panel; Charcoal colour; Returns to match panel colour; Mounted to wall surface securely
- B** Avenir LT Std; 85 Heavy; 18mm cap-height; Optical kerning; Tracking (0); Left aligned; White; Direct print or vinyl
- C** Map; Printed on vinyl or similar
- D** Poster frame; Black aluminum or similar

Use

Sign, where a campus map can be used to display exact locations, give users the confidence to navigate intuitively.

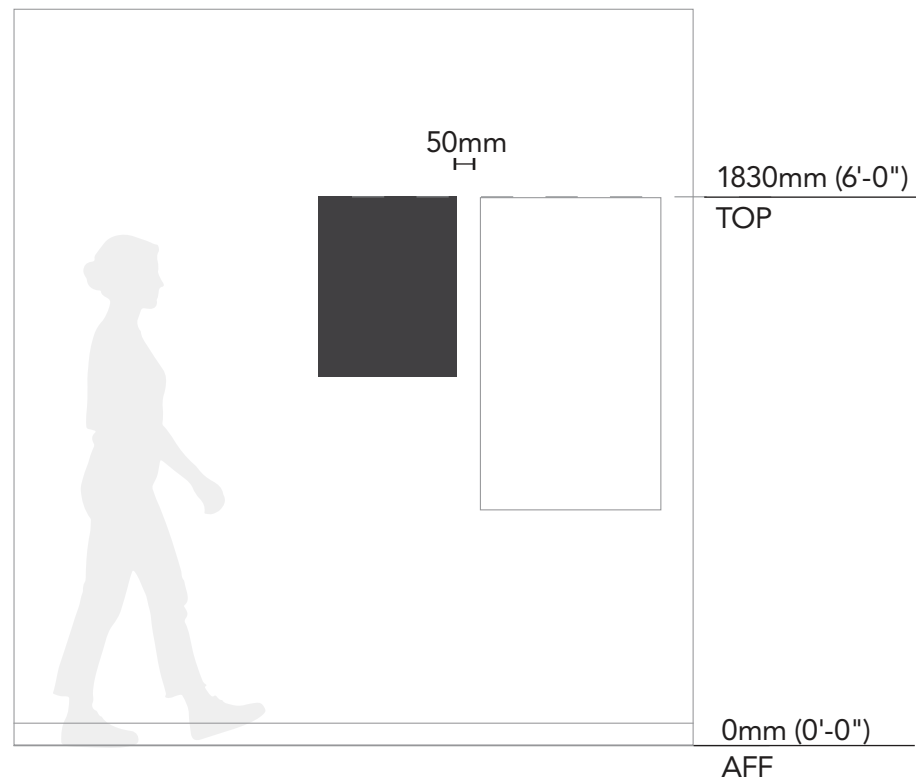

4 Elevation
Scale: 1:25

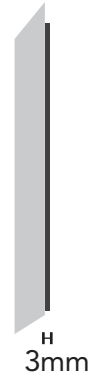
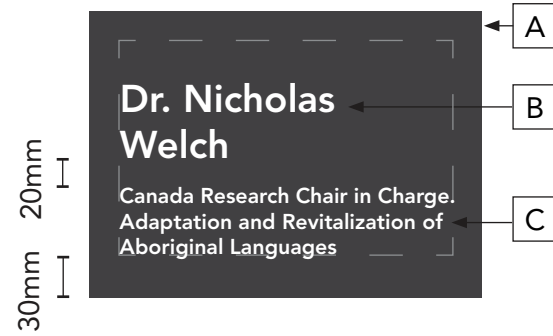

1 Layout
Scale: 1:5

2 Section
Scale: 1:5

Description

- A 3mm-thick acrylic panel; Charcoal colour; Returns to match panel colour; Mounted to wall surface securely
- B Avenir LT Std; 85 Heavy; 18mm cap-height; Optical kerning; Tracking (0); Left aligned; White; Direct print or vinyl
- C Avenir LT Std; 85 Heavy; 10mm cap-height; Optical kerning; Tracking (0); Left aligned; White; Direct print or vinyl

Use

Title, dedication and donor signs can be used to acknowledge distinguished and important, faculty, staff projects, or historic accomplishments.

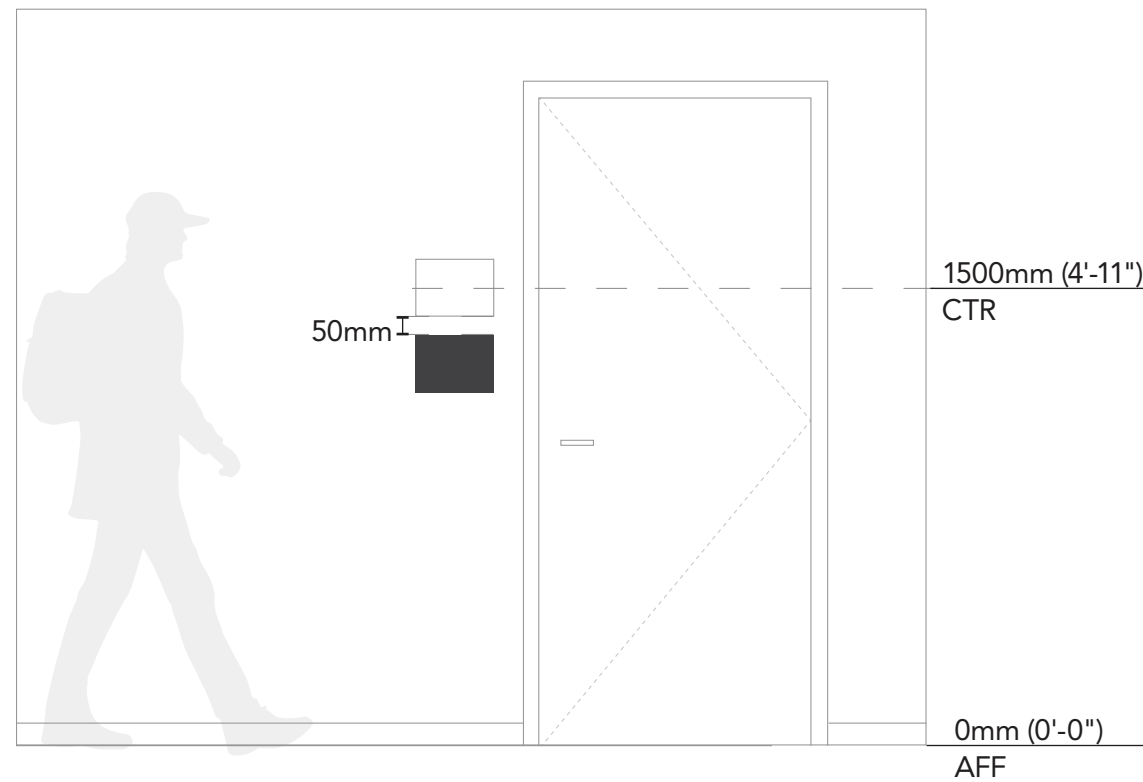

3 Elevation
Scale: 1:25

C.02 TD & D - B

Portrait

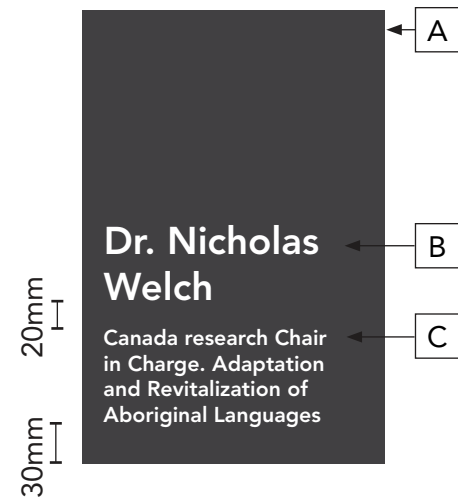

1 Layout

Scale: 1:5

Introduction

Signage

Wayfinding

Branding

38

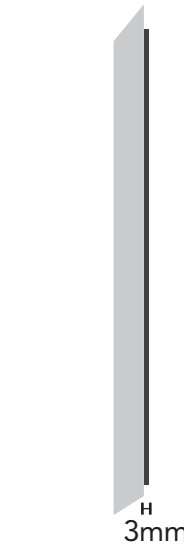

2 Section

Scale: 1:5

Description

- A 3mm-thick acrylic panel; Charcoal colour; Returns to match panel colour; Mounted to wall surface securely
- B Avenir LT Std; 85 Heavy; 18mm cap-height; Optical kerning; Tracking (0); Left aligned; White; Direct print or vinyl
- C Avenir LT Std; 85 Heavy; 10mm cap-height; Optical kerning; Tracking (0); Left aligned; White; Direct print or vinyl

Use

Title, dedication and donor signs can be used to acknowledge distinguished and important, faculty, staff projects, or historic accomplishments.

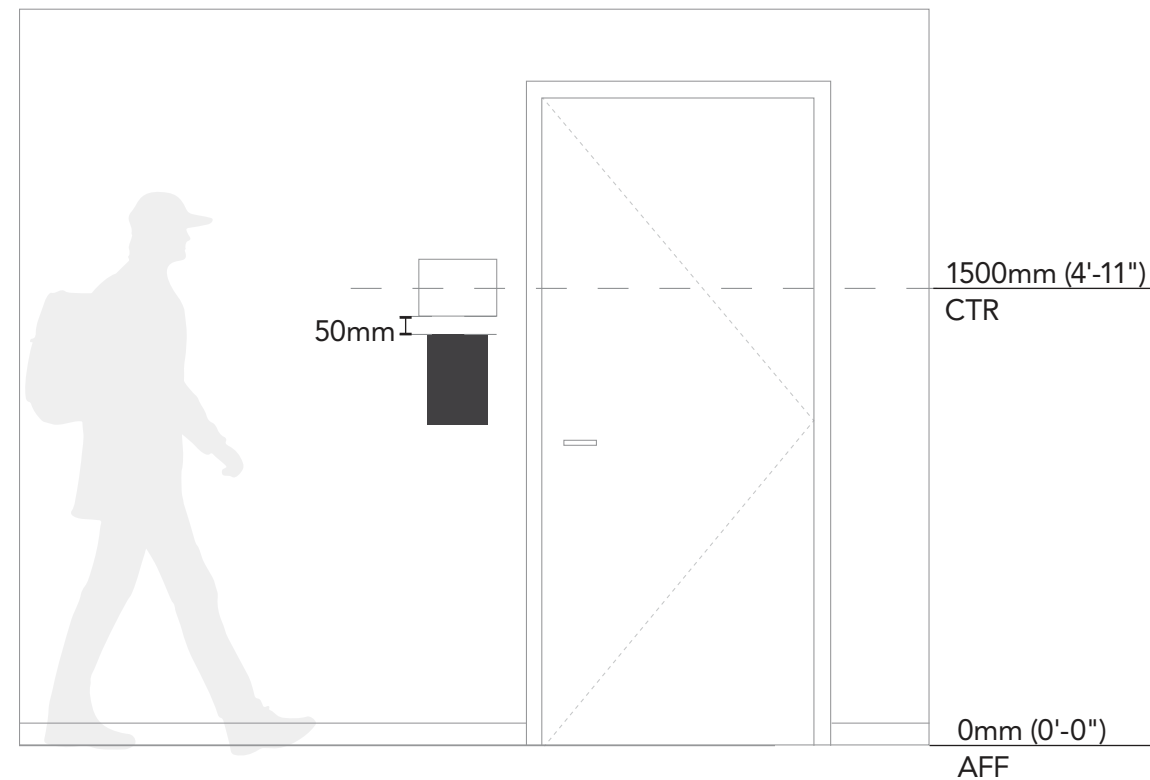

3 Elevation

Scale: 1:25

C.03 Donor

Portrait

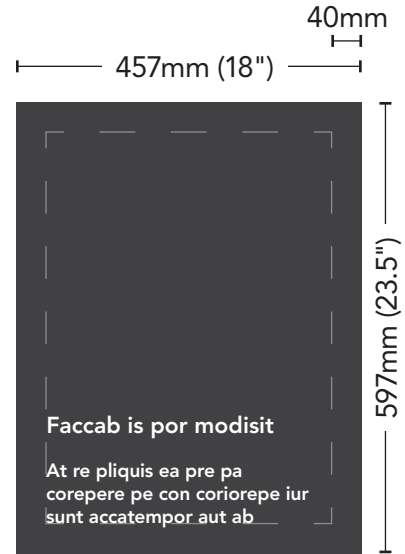

1 Layout
Scale: 1:10

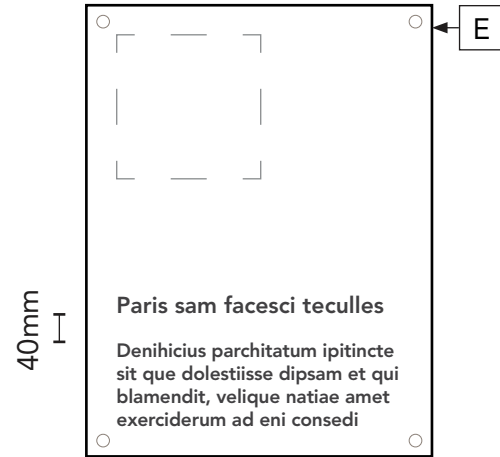
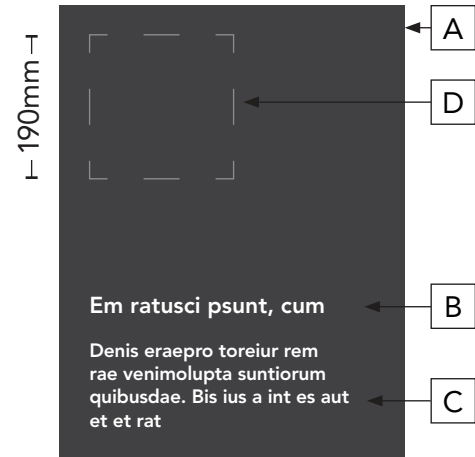

2 Layout: Glass
Scale: 1:10

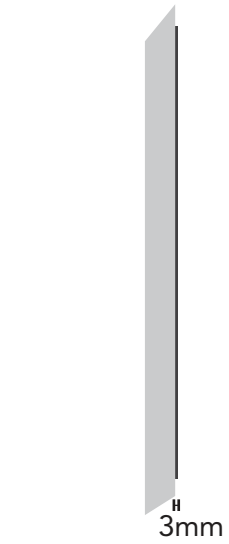

3 Section
Scale: 1:10

Description

- A** 3mm-thick acrylic panel; Charcoal colour; Returns to match panel colour; Mounted to wall surface securely
- B** Avenir LT Std; 85 Heavy; 22.5mm cap-height; Optical kerning; Tracking (0); Left aligned; White or black; Direct print or vinyl
- C** Avenir LT Std; 85 Heavy; 18mm cap-height; Optical kerning; Tracking (0); Left aligned; White or black; Direct print or vinyl
- D** Photography; Direct print or vinyl; color to be defined by Office of Development
- E** 2.4mm glass panel; Mounted to wall surface securely with standoffs

Use

Donor signs can be used to acknowledge, reward and recognize donors, their accomplishments and encourage prospective ones. For further details confirm with the Office of Development.

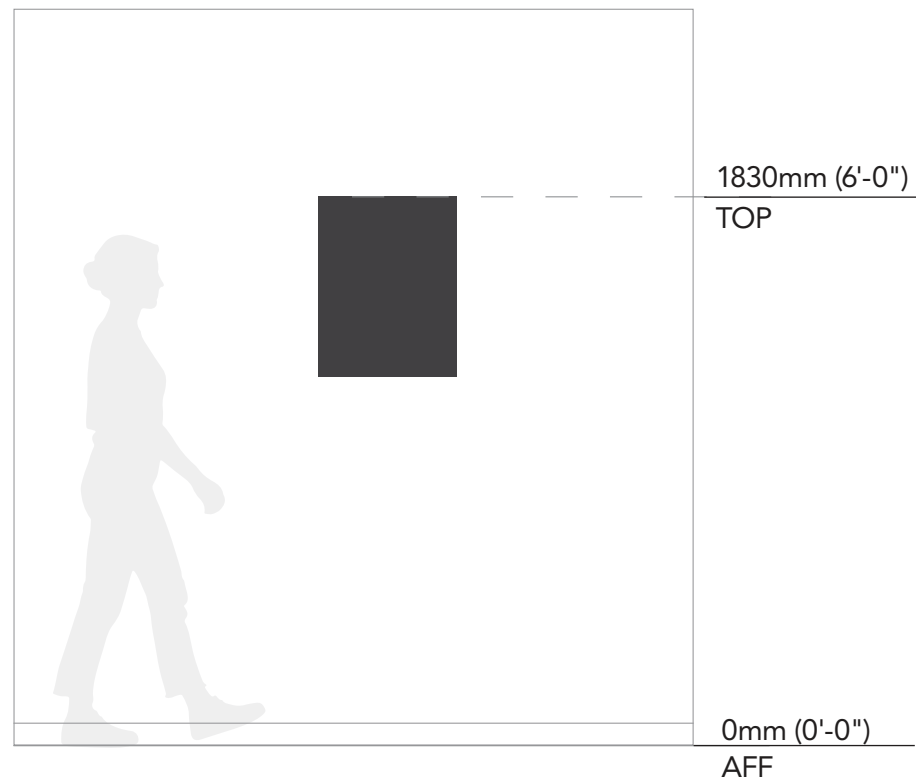

4 Elevation
Scale: 1:25

C.1 Infographics

Info

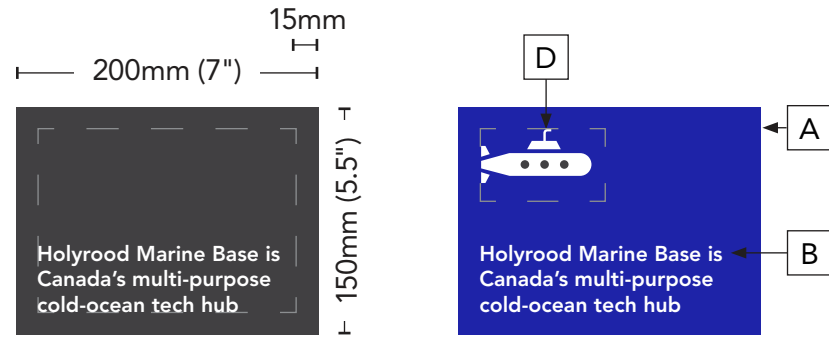

1 Layout

Scale: 1:5

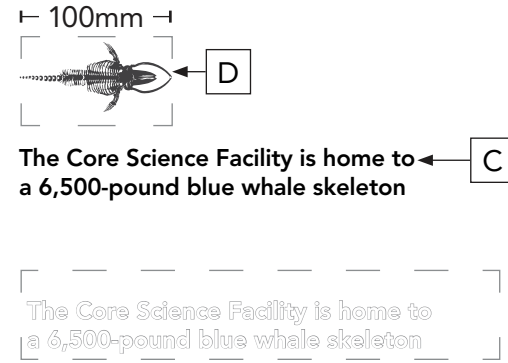

2 Layout: Vinyl

Scale: 1:5

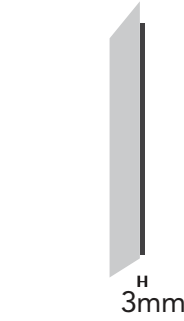

3 Section

Scale: 1:5

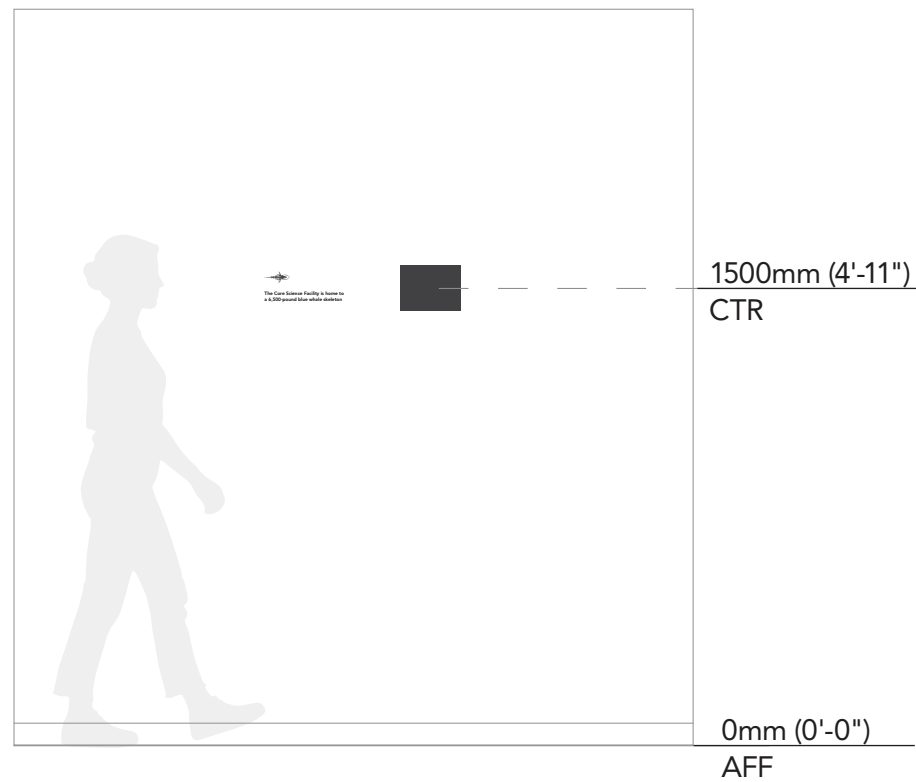

4 Elevation

Scale: 1:25

Description

- A** 3mm-thick acrylic panel; colour to change per sign; Returns to match panel colour; Mounted to wall surface securely
- B** Avenir LT Std; 85 Heavy; 10mm cap height; Optical kerning; Tracking (0); Left aligned; White
- C** Avenir LT Std; 85 Heavy; 12mm cap height; Optical kerning; Tracking (0); Left aligned; Charcoal (White if needs contrast); Die-cut vinyl
- D** Pictogram; White (Charcoal if needs contrast); Direct print or die-cut vinyl; Size relative to signage layout in scale

Use

Infographics, as a way to showcase MUN's extensive history and culture. These are specific moments of discovery that educate users and can have a wayfinding purpose.

C.1 Infographics

Graphics

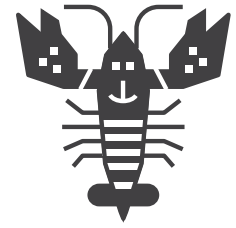

1 Lobster
Scale: NTS



2 Whale
Scale: NTS

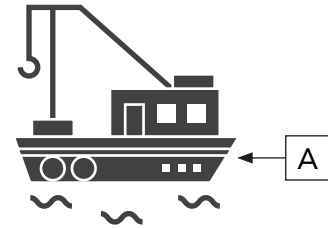

3 Fishing Boat
Scale: NTS



4 Sea-Hawk
Scale: NTS



5 Scuba Diver
Scale: NTS

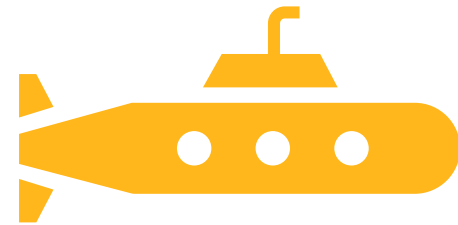

6 Submarine
Scale: NTS

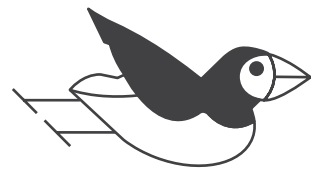

7 Puffins
Scale: NTS

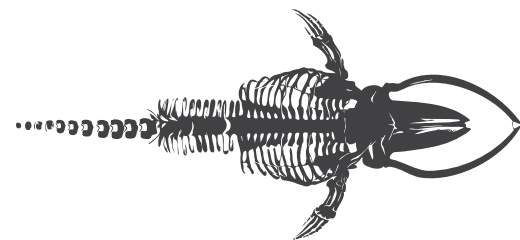

8 CSF Whale
Scale: NTS

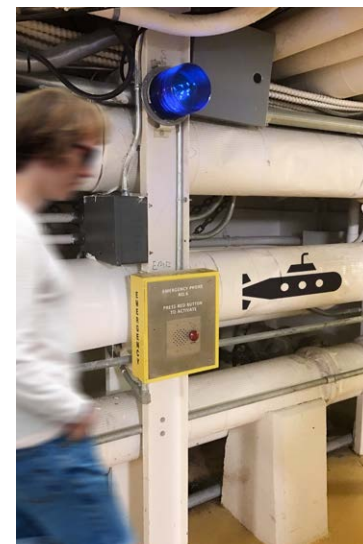

Description

A Die-cut vinyl decal; Charcoal or colour of choice; Size to be defined depending on the specific location

Use

Infographics, as a way to showcase MUN's extensive history and culture. These are specific moments of discovery that educate users and can have a wayfinding purpose.

C.2 Surface Colour

Paint

Introduction

Signage

Wayfinding

Branding

42

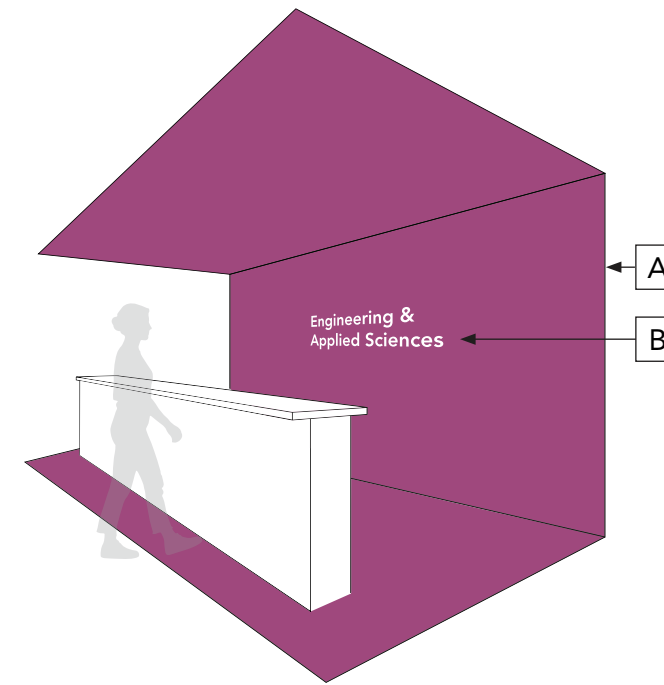

1 Axonometrics

Scale: NTS

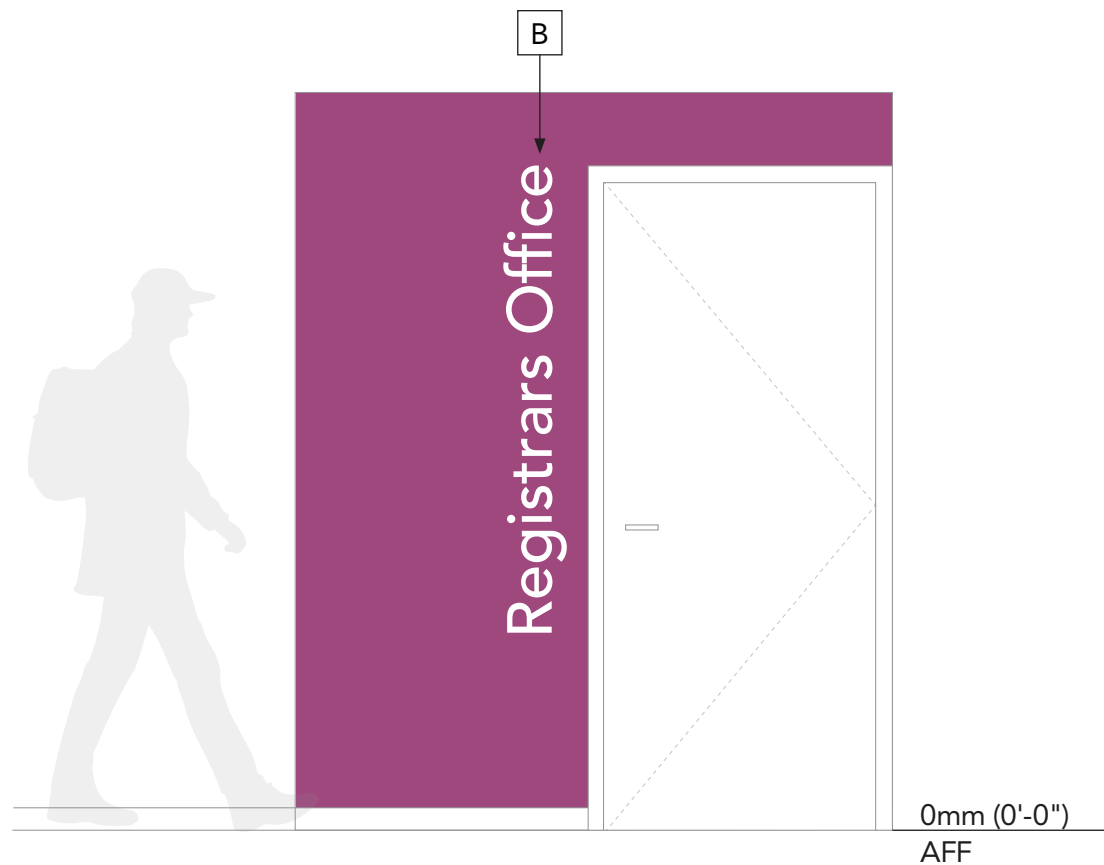

2 Elevation

Scale: 1:25

Description

- A** Painted wall, ceiling and/or floor with the Facilities Management Palette Colour that corresponds to the specific department
- B** Refer to Sign Type B.03 for text specifications

Use

Surface colours used as a background to recognize and identify the entry of a specific department or area and can have a wayfinding purpose.

Facilities Management Palette

	
Benjamin Moore Starry Night Blue 2067-20	Benjamin Moore Pre-Dawn Sky 2075-30
	
Benjamin Moore Yellow Flash 2021-10	Benjamin Moore Neon Red 2087-10
	
Benjamin Moore New Lime 2025-30	Benjamin Moore Naples Blue 2057-30

C.2 Surface Graphics

Wallcovering

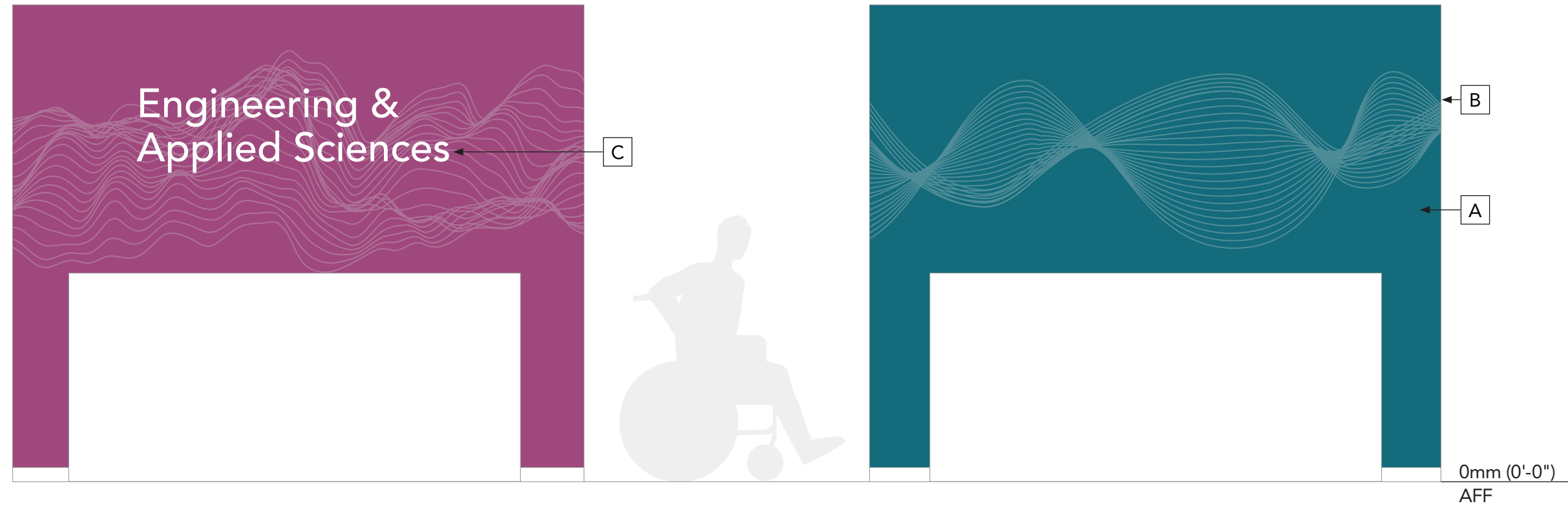

1 Elevation
Scale: 1:25

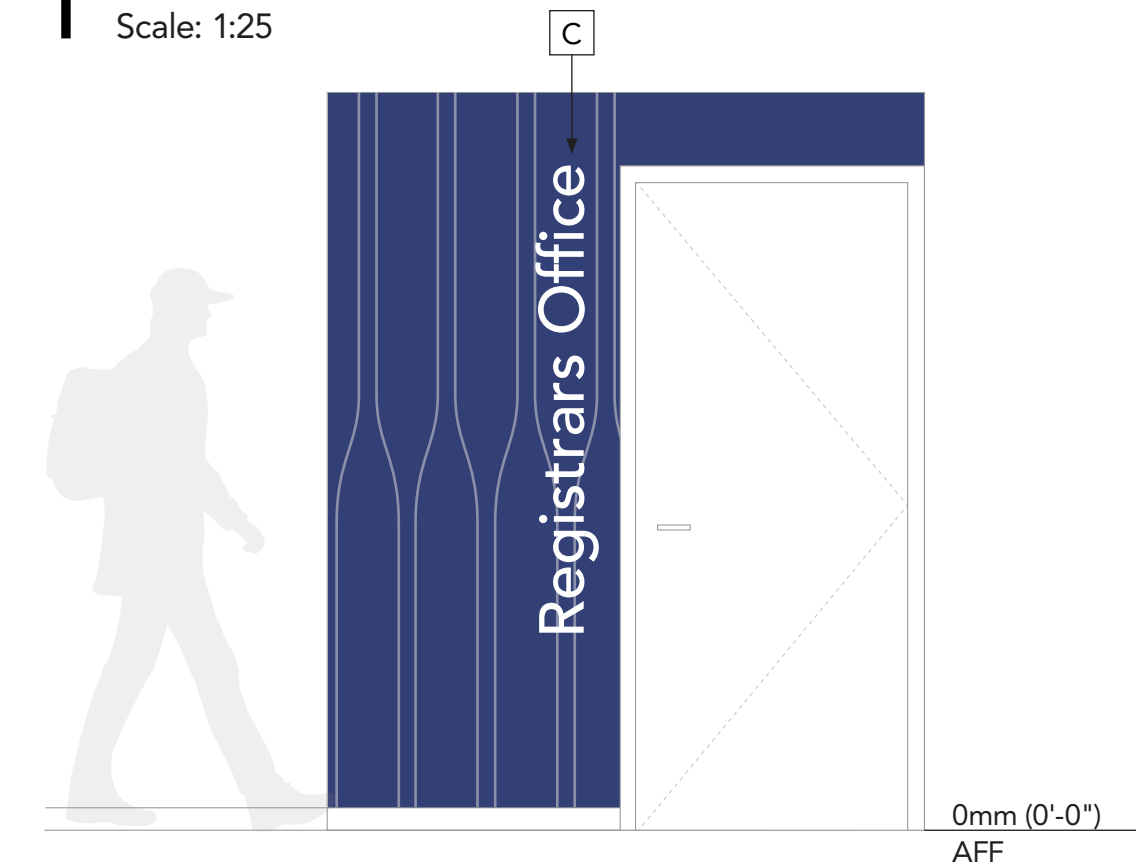

2 Elevation: Entry
Scale: 1:25

Description

- A** DreamScape wall covering or similar; finish to have a durable dry wall quality; installed with no visible seams; artwork to be requested
- B** All wall edges to have J-bead guards from floor to ceiling when not butted up against another wall
- C** Refer to Sign Type B.03 for text specifications

Use

Surface graphics used to recognize and identify the entry of a specific department or area, this incorporates MUN's brand and culture through custom patterns and can have a wayfinding purpose.

C.30 C.31 Glass Film

Linear

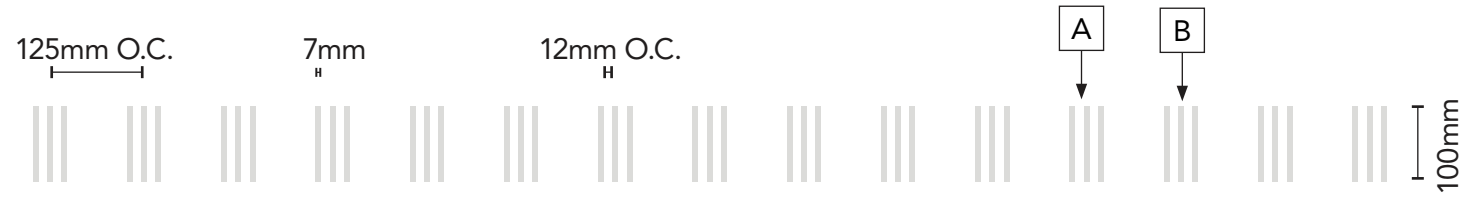

1 Layout: C.30 Strip Vertical
Scale: 1:10

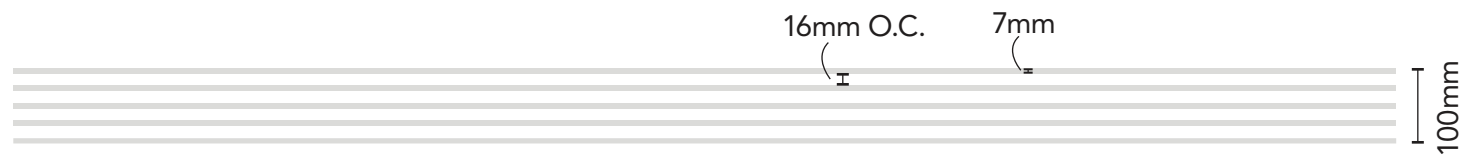

2 Layout: C.31 Strip Horizontal
Scale: 1:10

Description

- A** Die-cut Polymeric Etch Film or graphic printed in Polymeric Etch Film colour on optically clear vinyl sheet
- B** Installed on second surface (interior side of glass); Film to be installed with no visible seams

Use

Glass film, required per code, on all glass surfaces. Designs relate to MUN's brand and culture.



1 Elevation: C.30 Strip Vertical
Scale: 1:25

2 Elevation: C.31 Strip Horizontal
Scale: 1:25

C.32, C.33 Glass Film

Linear

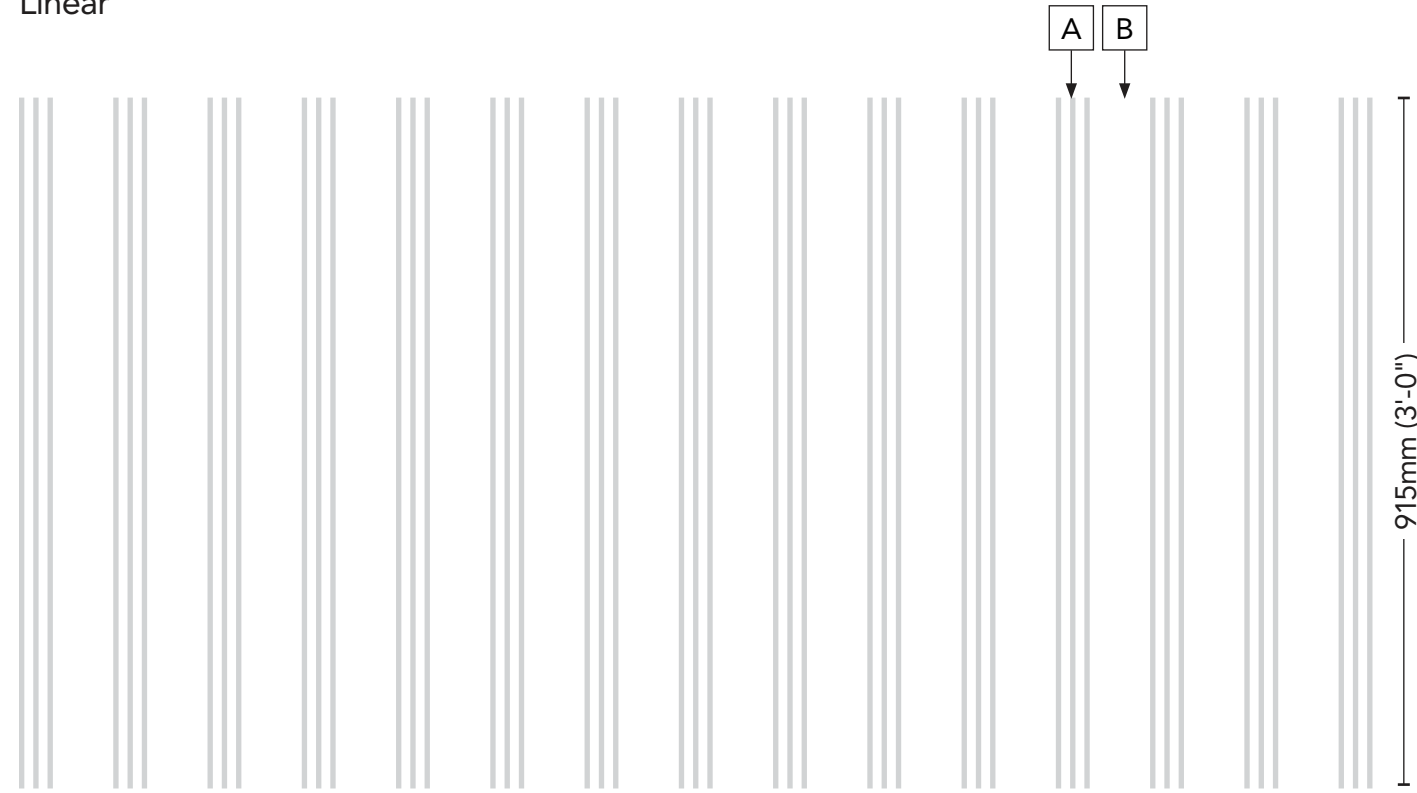

1 Layout: C.32 Band Vertical
Scale: 1:10

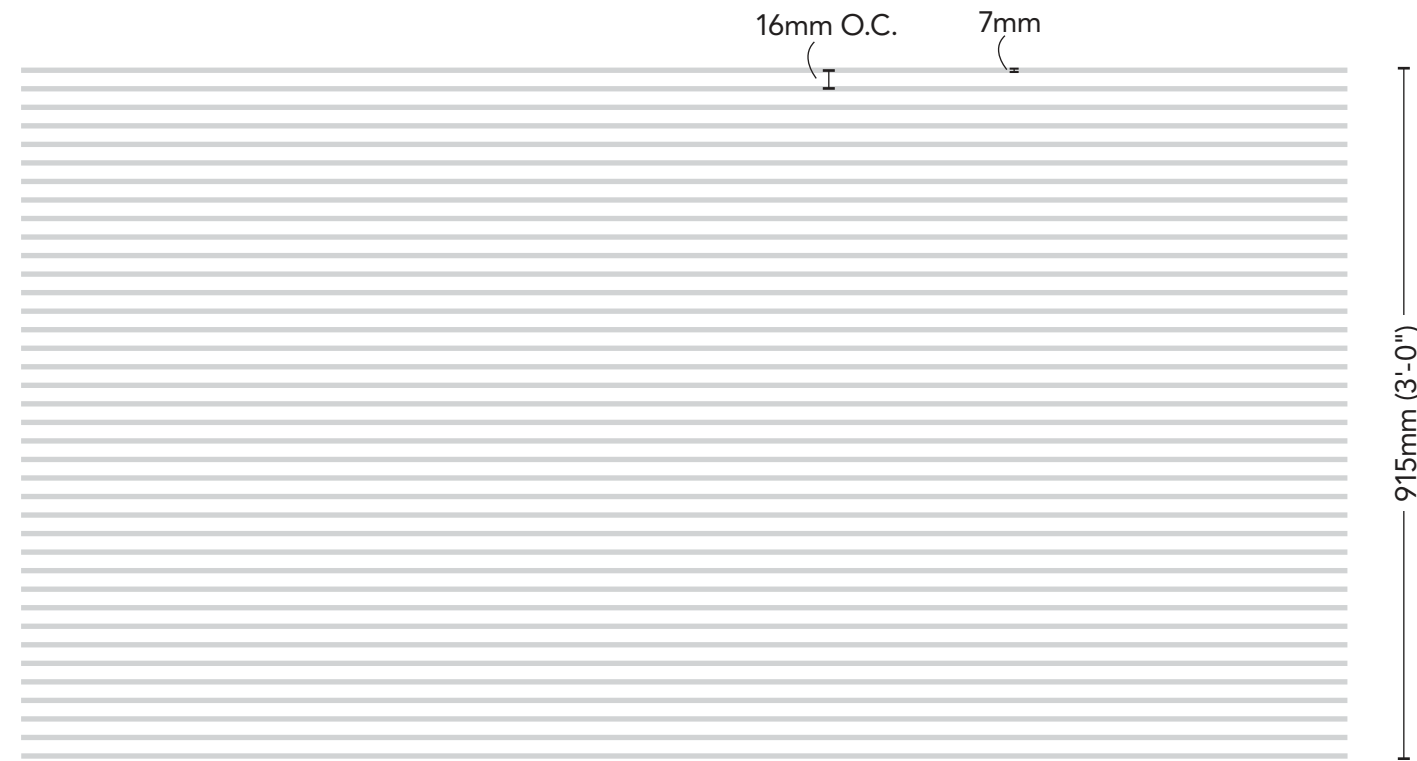

2 Layout: C.33 Band Horizontal
Scale: 1:10

Description

- A** Die-cut Polymeric Etch Film or graphic printed in Polymeric Etch Film colour on optically clear vinyl sheet
- B** Installed on second surface (interior side of glass); Film to be installed with no visible seams

Use

Glass film, required per code, on all glass surfaces. Designs relate to MUN's brand and culture.

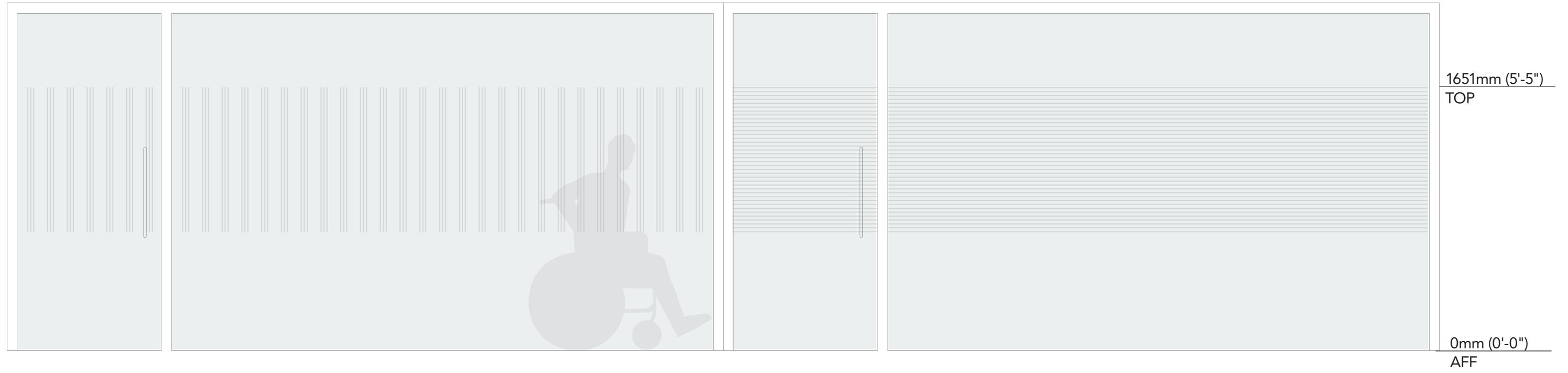

1 Elevation: C.32 Band Vertical
Scale: 1:25

2 Elevation: C.33 Band Horizontal
Scale: 1:25

C.34, C.35 Glass Film

Privacy

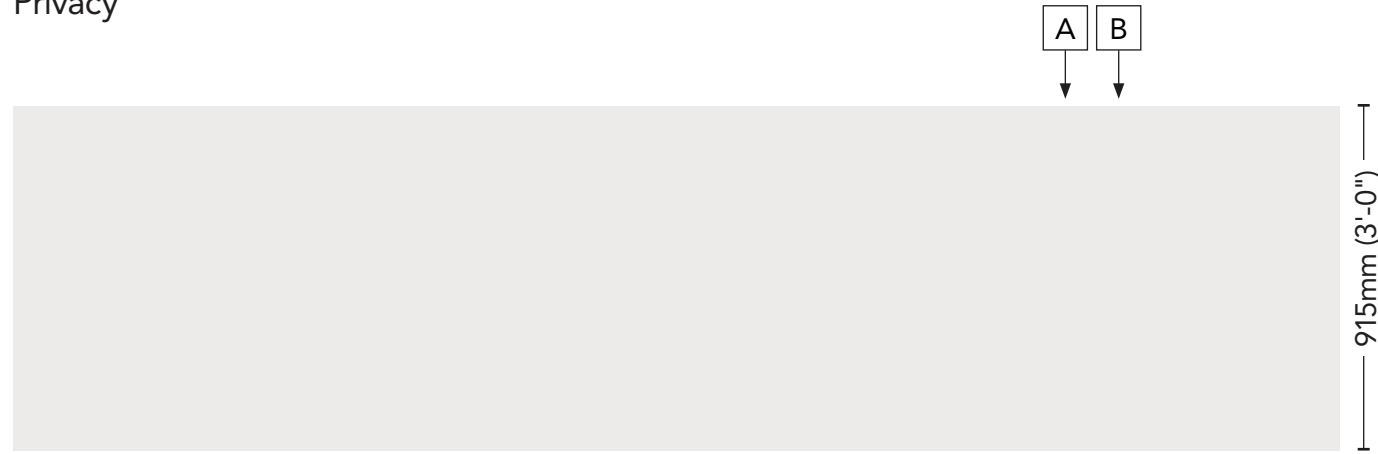

1 Layout: C.34 Band
Scale: 1:20



2 Layout: C.35 Band Gradient
Scale: 1:20

Description

- A** Polymeric Etch Film or graphic printed in Polymeric Etch Film colour on optically clear vinyl sheet
- B** Installed on second surface (interior side of glass); Film to be installed with no visible seams

Use

Glass film, required per code, on all glass surfaces. Designs relate to MUN's brand and culture and these to provide privacy.

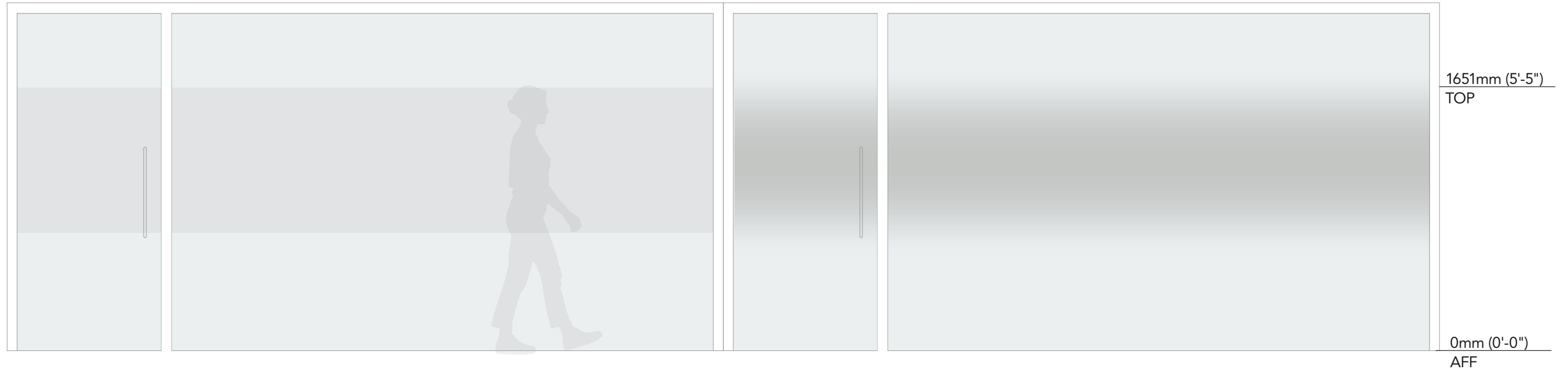

1 Elevation: C.34 Band
Scale: 1:25

2 Elevation: C.35 Band Gradient
Scale: 1:25

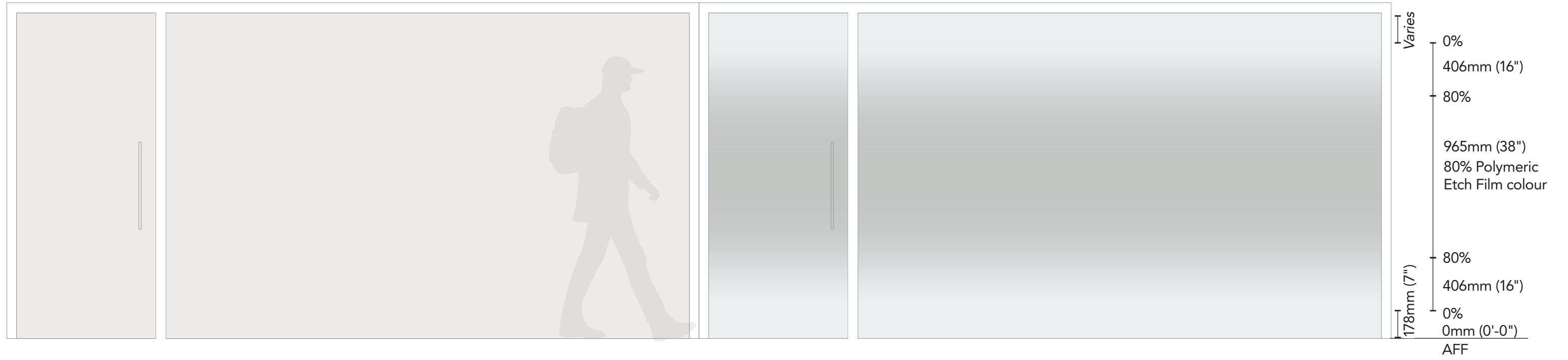

1 Elevation: C.36 Full
Scale: 1:25

2 Elevation: C.37 Full Gradient
Scale: 1:25

C.38, C.39 Glass Film

Rib



1 Layout: C.38 Strip
Scale: 1:10

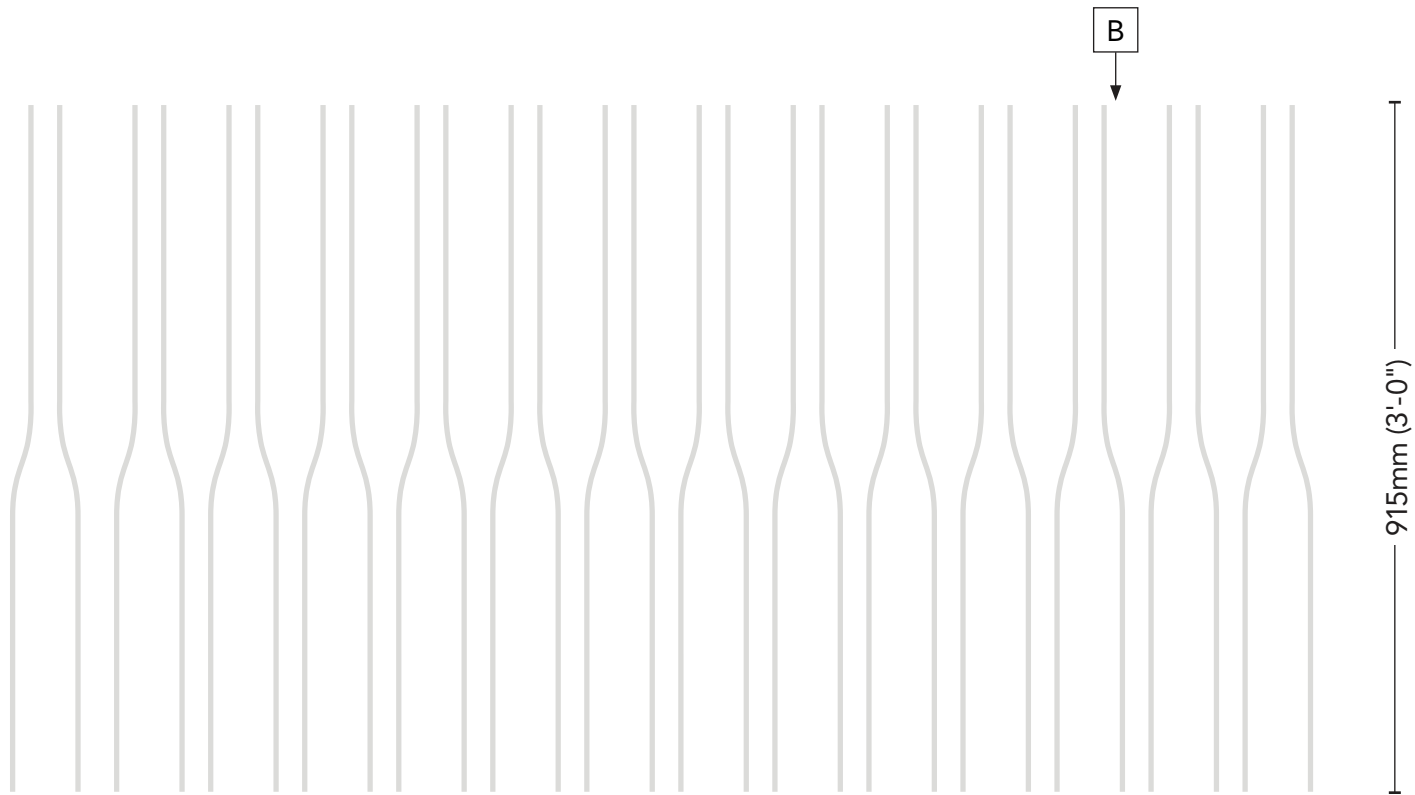

2 Layout: C.39 Band
Scale: 1:10

Description

- A** Die-cut Polymeric Etch Film or graphic printed in Polymeric Etch Film colour on optically clear vinyl sheet
- B** Installed on second surface (interior side of glass); Film to be installed with no visible seams

Use

Glass film, required per code, on all glass surfaces. Designs relate to MUN's brand and culture.

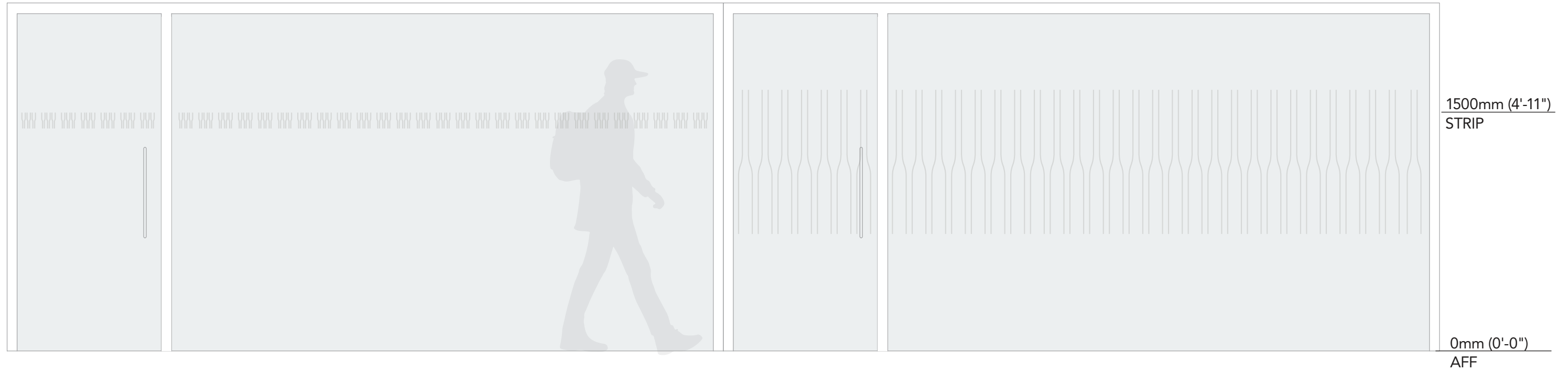

1 Elevation: C.38 Strip
Scale: 1:25

2 Elevation: C.39 Band
Scale: 1:25

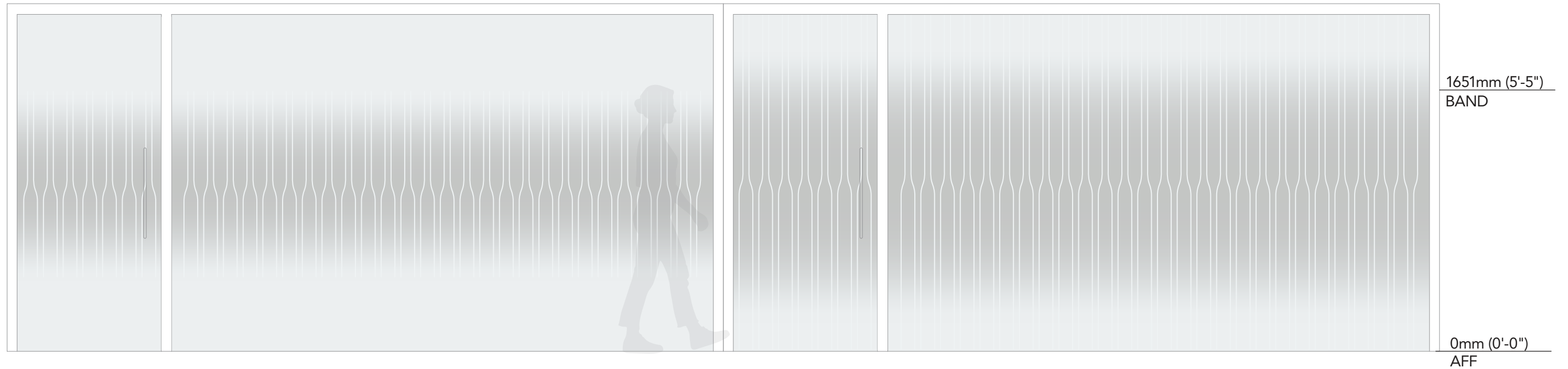

3 Elevation: C.40 Band Gradient
Scale: 1:25

4 Elevation: C.41 Full Gradient
Scale: 1:25

C.42, C.43 Glass Film

Coast



1 Layout: C.42 Strip
Scale: 1:10

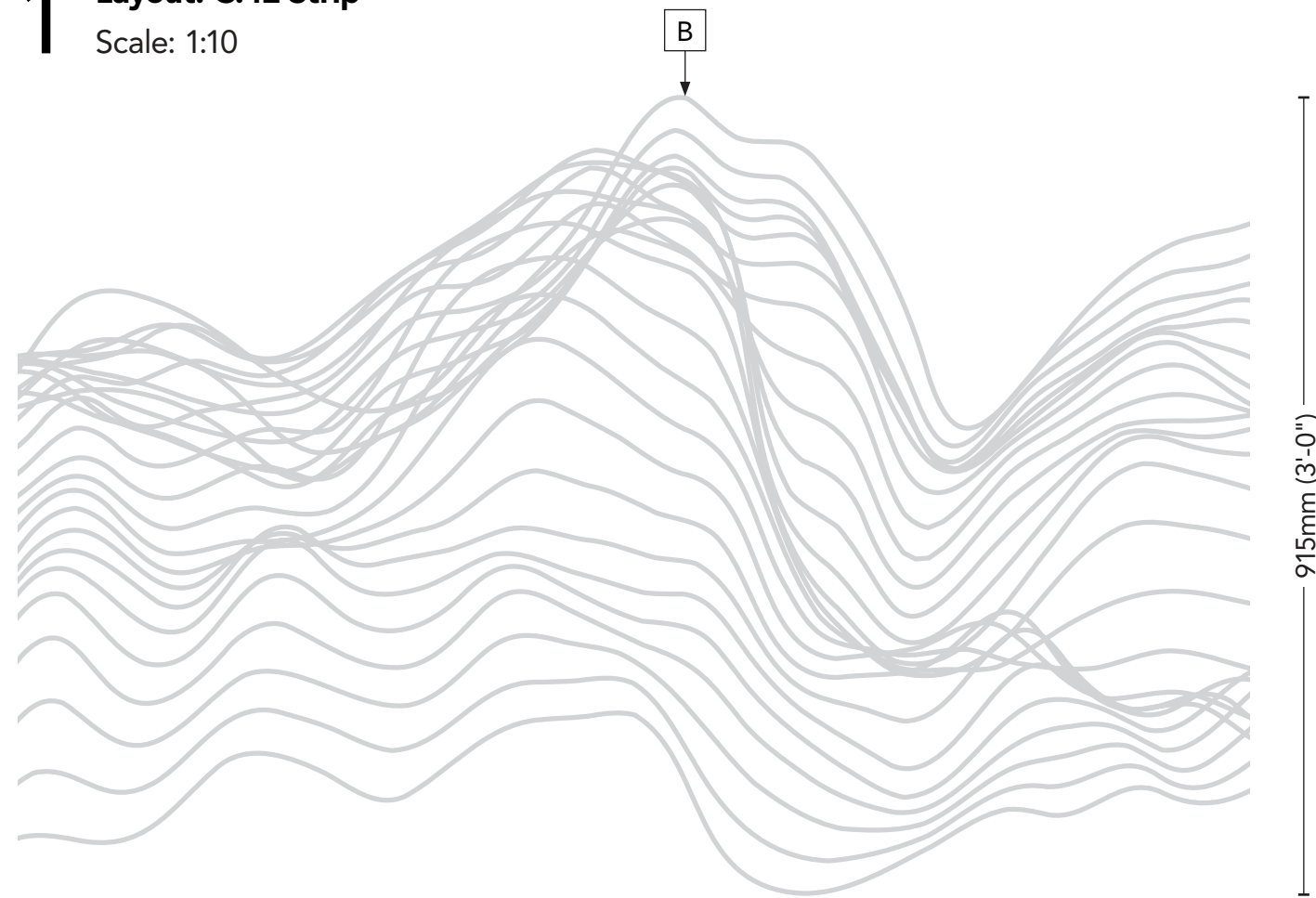

2 Layout: C.43 Band
Scale: 1:10

Description

- A** Die-cut Polymeric Etch Film or graphic printed in Polymeric Etch Film colour on optically clear vinyl sheet
- B** Installed on second surface (interior side of glass); Film to be installed with no visible seams

Use

Glass film, required per code, on all glass surfaces. Designs relate to MUN's brand and culture.

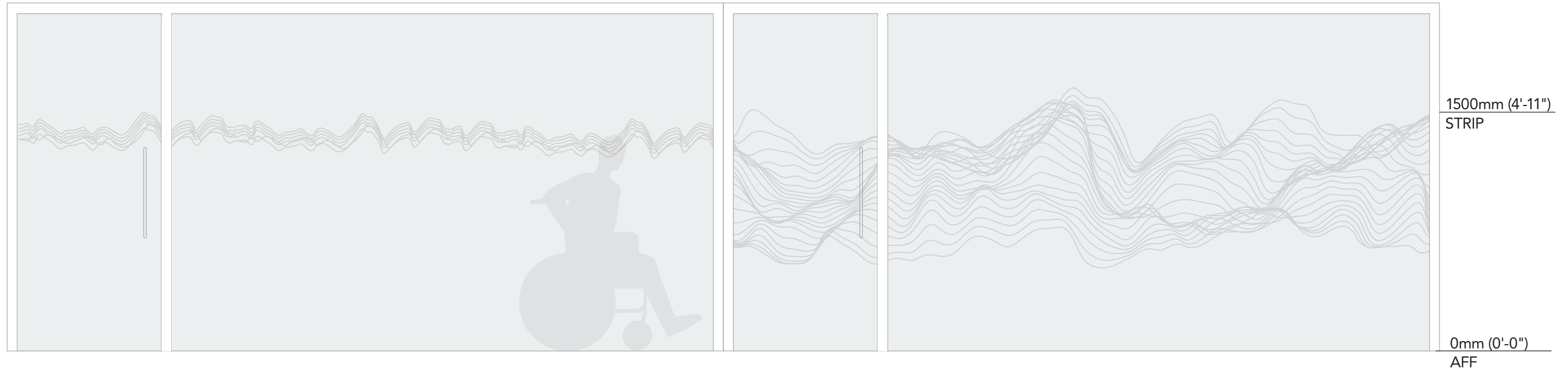

1 Elevation: C.42 Strip
Scale: 1:25

2 Elevation: C.43 Band
Scale: 1:25

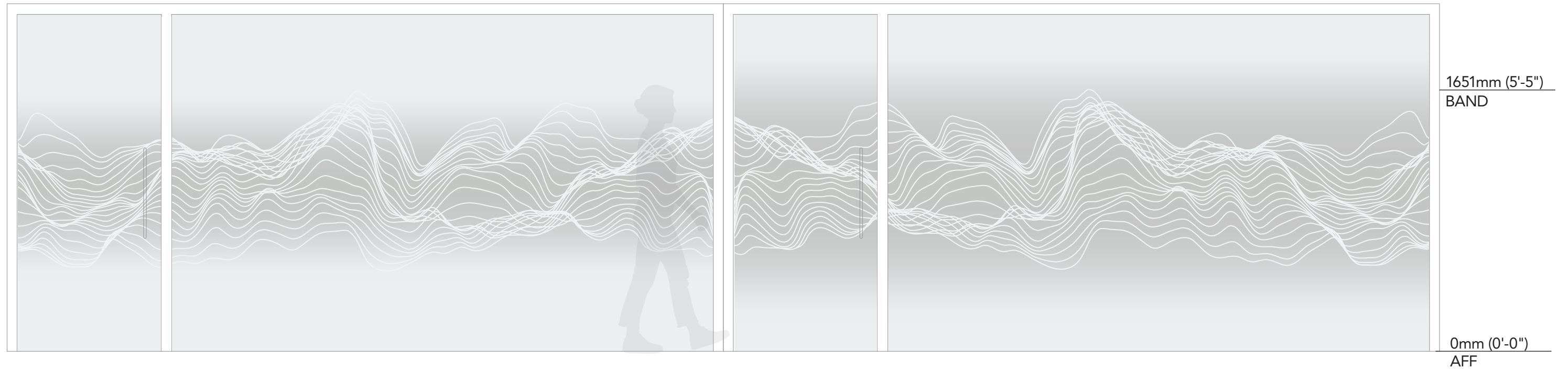

3 Elevation: C.44 Band Gradient
Scale: 1:25

4 Elevation: C.45 Full Gradient
Scale: 1:25



1 Layout: C.46 Strip
Scale: 1:10

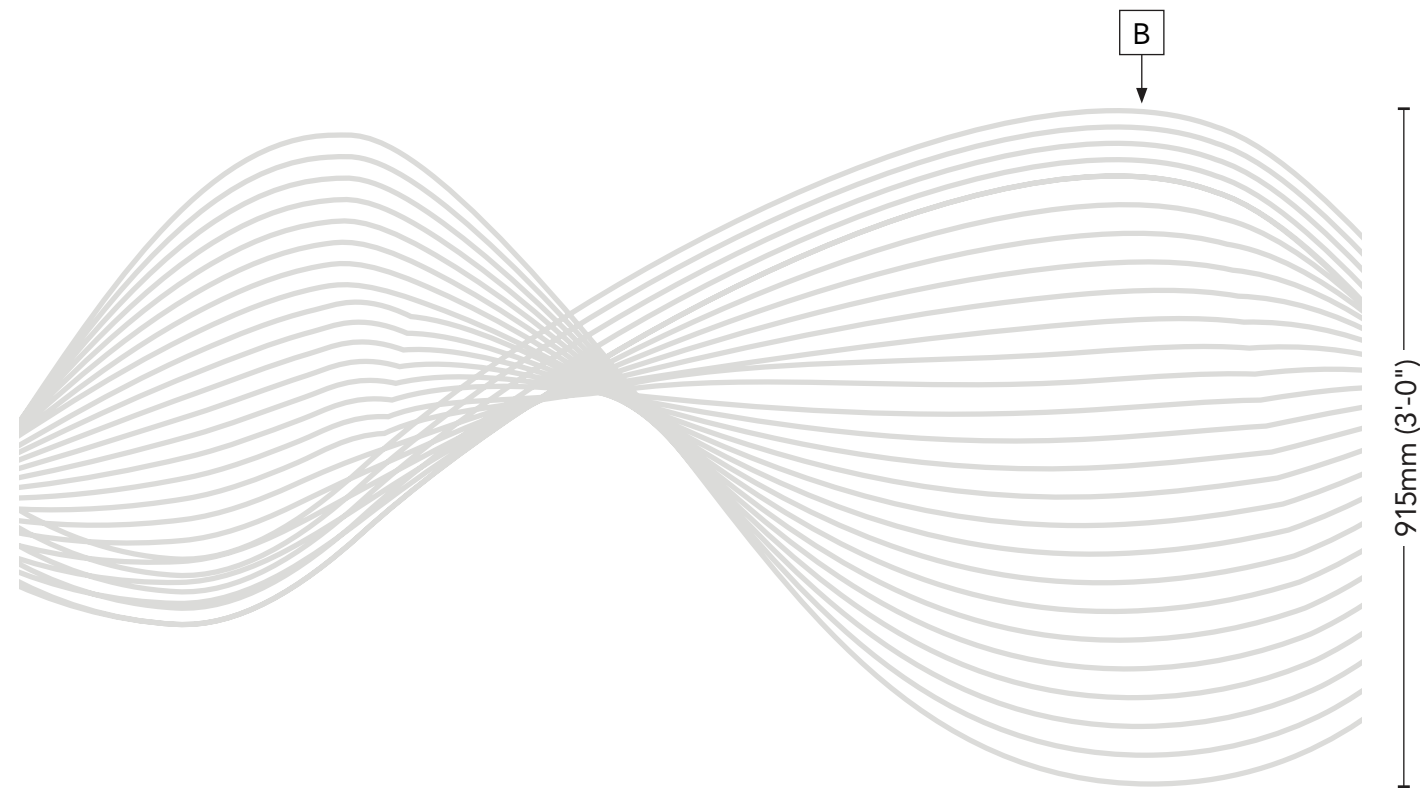

2 Layout: C.47 Band
Scale: 1:10

Description

- A** Die-cut Polymeric Etch Film or graphic printed in Polymeric Etch Film colour on optically clear vinyl sheet
- B** Installed on second surface (interior side of glass); Film to be installed with no visible seams

Use

Glass film, required per code, on all glass surfaces. Designs relate to MUN's brand and culture.

Route

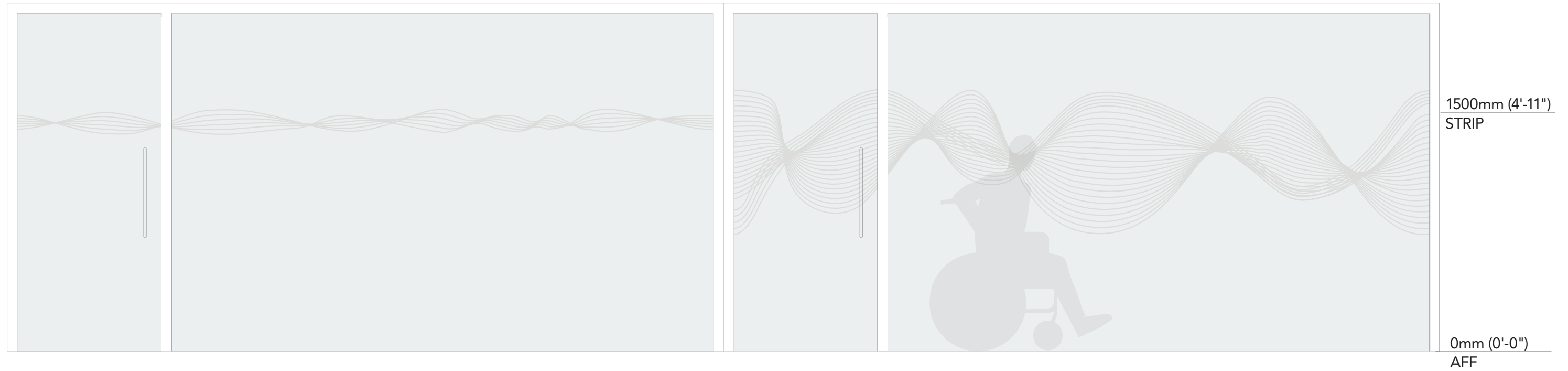

1 Elevation: C.46 Strip
Scale: 1:25

2 Elevation: C.47 Band
Scale: 1:25

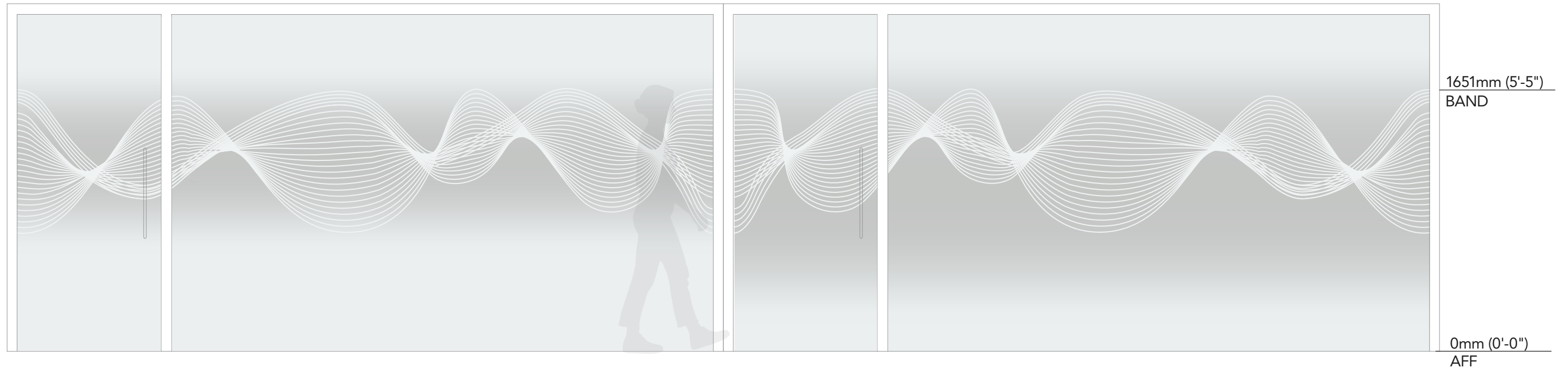

3 Elevation: C.48 Band Gradient
Scale: 1:25

4 Elevation: C.49 Full Gradient
Scale: 1:25

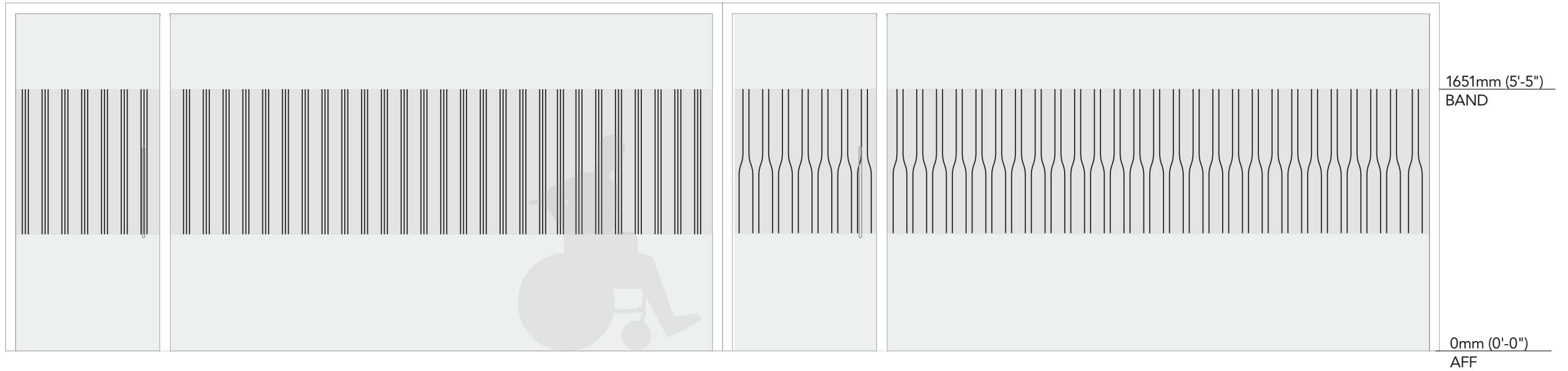

1 Elevation: C.50 Linear
Scale: 1:25

2 Elevation: C.51 Rib
Scale: 1:25

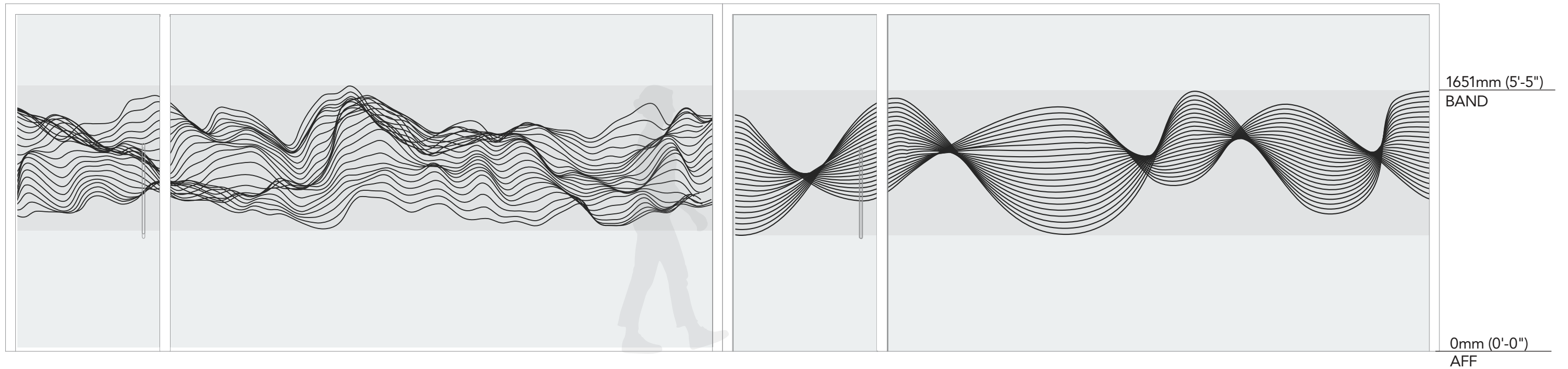

3 Elevation: C.52 Coast
Scale: 1:25

4 Elevation: C.53 Route
Scale: 1:25

Appendix (Future)

Currently not included in
Interior Signage Manual 1.0

Pictogram Usage

Pictograms will be a key element to the design as they will have a large impact on the signs from a visual perspective but also from an informational standpoint as these should be universally understood by anyone

*4.5.6.3 Tactile Pictograms and Symbols

- a. Raised between 0.8-1.5mm above surface
- b. At least 150mm in height
- c. Accompanied by uncontracted braille below pictogram
- d. Colour-contrasted with background by at least 70%

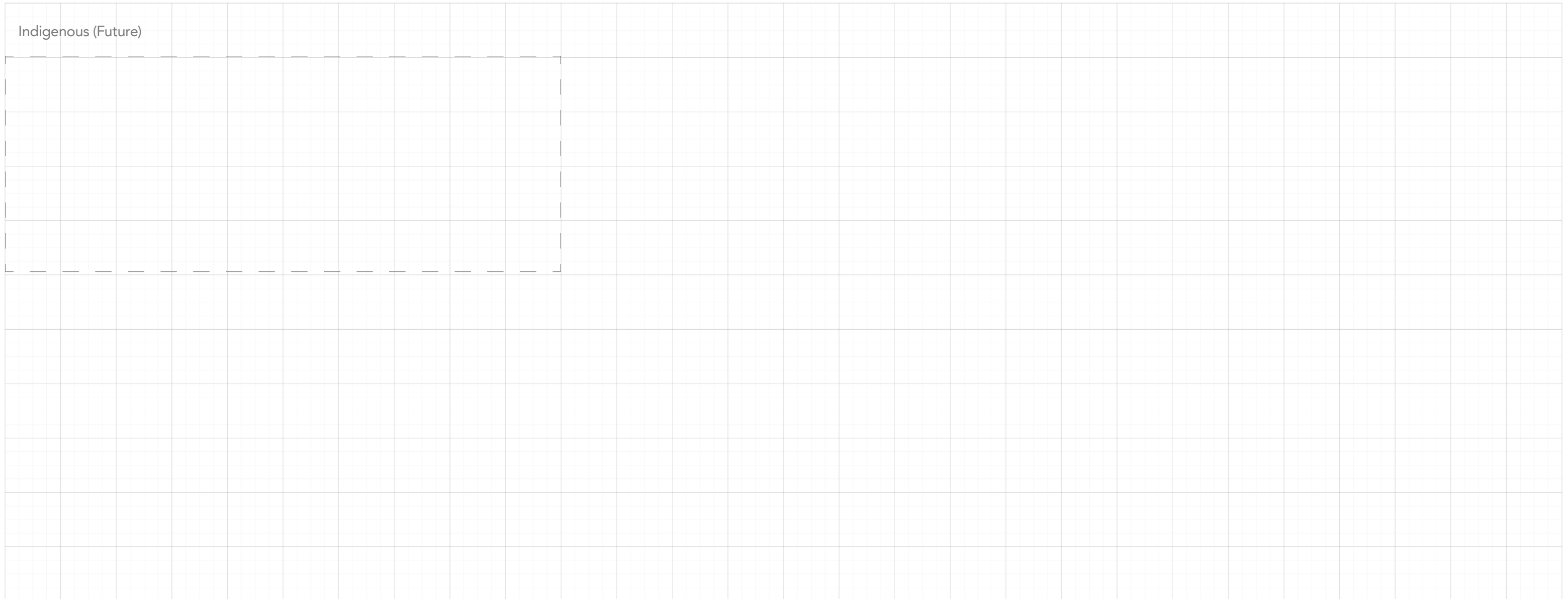

Room ID - A

Standard

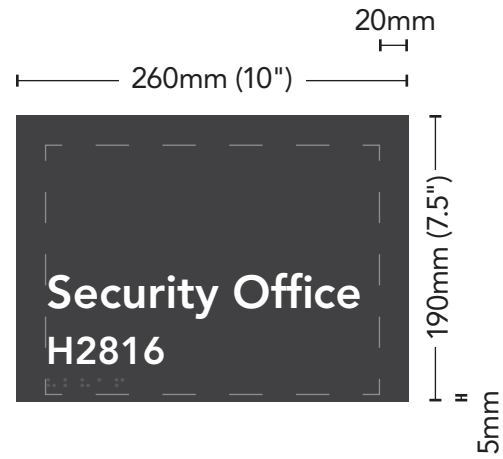

1 Layout

Scale: 1:5

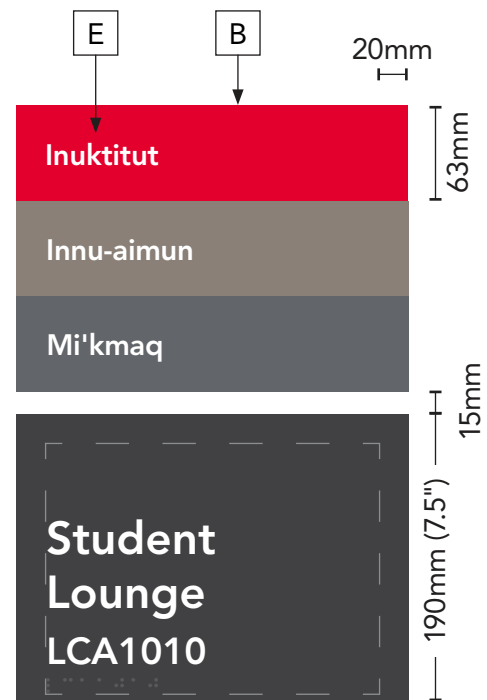

2 Layout: Translations

Scale: 1:5

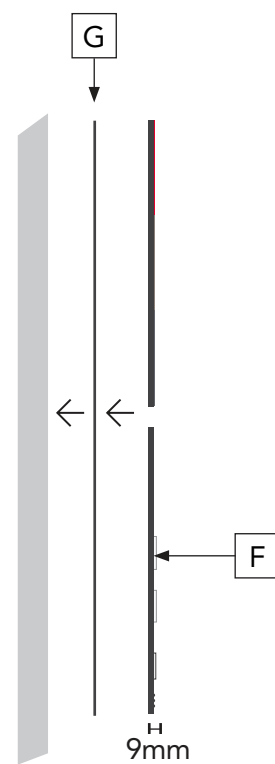

3 Section

Scale: 1:5

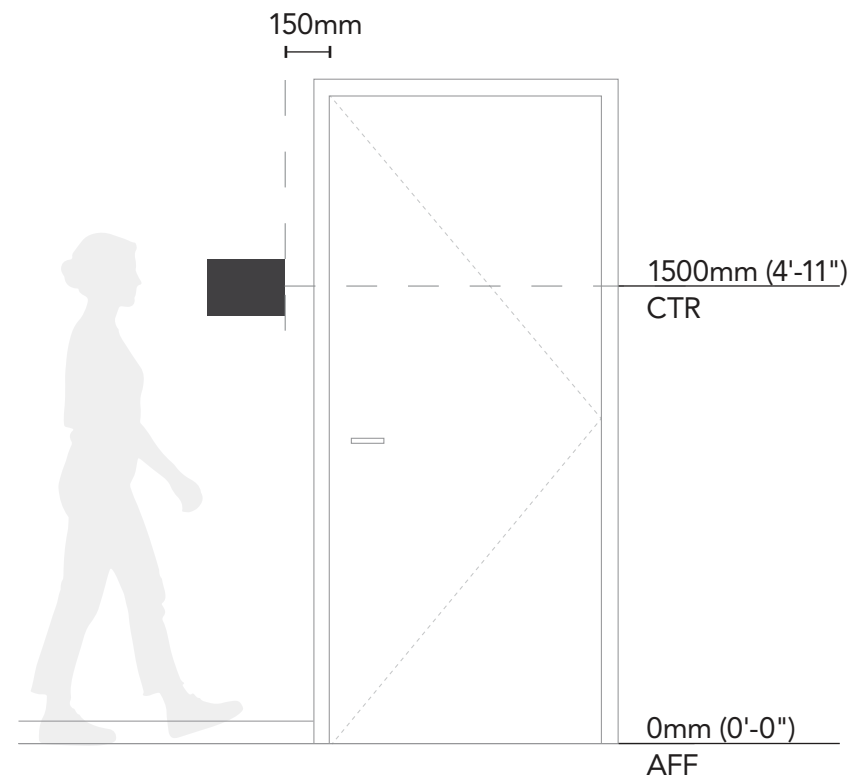

4 Elevation

Scale: 1:25

Description

- A** 3mm-thick acrylic panel; Charcoal colour; Returns to match panel colour; Mounted to wall surface securely
- B** 3mm-thick acrylic panel; Charcoal colour; Vinyl sticker with translation colour specifications applied to surface of panel; Mounted to wall surface securely
- C** Avenir LT Std; 85 Heavy; 22.5mm cap-height; Optical kerning; Tracking (0); Left aligned; White; Raised 0.8mm from panel
- D** Avenir LT Std; 85 Heavy; 18mm cap-height; Optical kerning; Tracking (0); Left aligned; White; Raised 0.8mm from panel
- E** Avenir LT Std; 85 Heavy; 14mm cap-height; Optical kerning; Tracking (0); Left aligned; White; Direct print or vinyl
- F** Braille; 10mm cap-height; Colour to match panel; Raised 0.8mm from panel; Message to include both room name and room number
- G** When mounted to glass surface, vinyl backer to be applied to same side of glass as sign to hide adhesive; Backer to match sign colour

Use

Sign for standard room identification with a fixed use, ie. Custodial Room, Security Office. Translations can be included at special request and are to be coordinated with the Office of Indigenous Affairs.

Room ID - B

Restroom

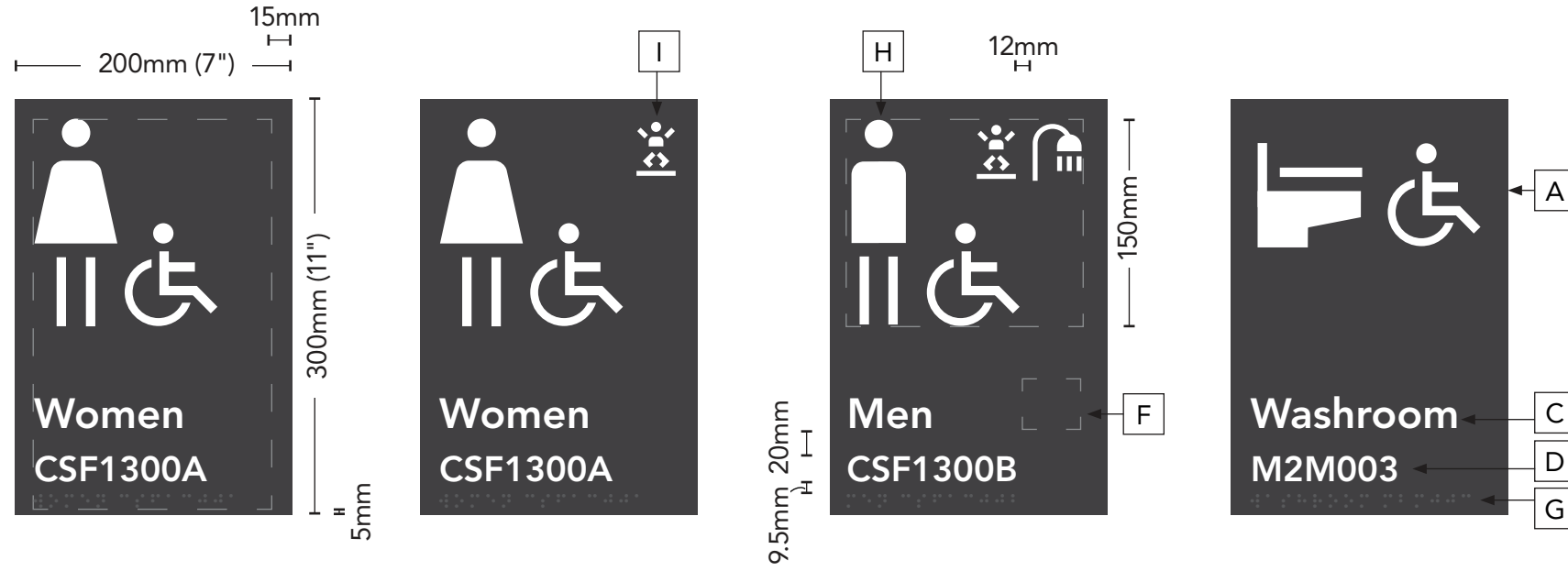

1 Layout

Scale: 1:5

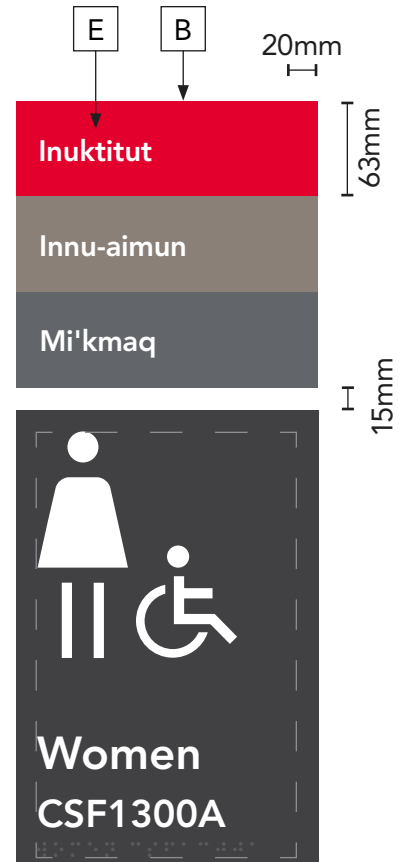

2 Layout: Translations

Scale: 1:5

3 Section

Scale: 1:5

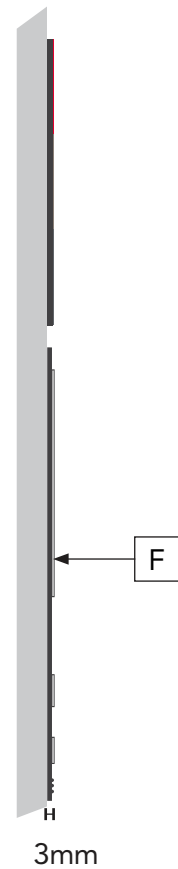

4 Elevation

Scale: 1:25

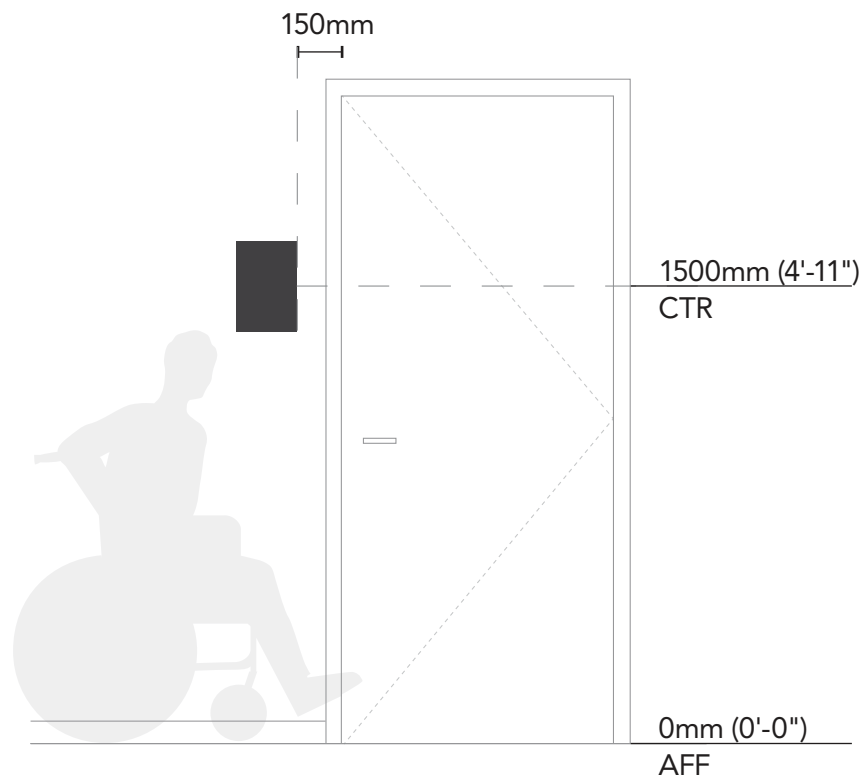

Description

- A 3mm-thick acrylic panel; Charcoal colour; Returns to match panel colour; Mounted to wall securely
- B 3mm-thick acrylic panel; Charcoal colour; Vinyl sticker with translation colour specifications applied to surface of panel; Mounted to wall surface securely
- C Avenir LT Std; 85 Heavy; 22.5mm cap-height; Optical kerning; Tracking (0); Left aligned; White; Raised 0.8mm from panel
- D Avenir LT Std; 85 Heavy; 18mm cap-height; Optical kerning; Tracking (0); Left aligned; White; Raised 0.8mm from panel
- E Avenir LT Std; 85 Heavy; 14mm cap-height; Optical kerning; Tracking (0); Left aligned; White; Direct print or vinyl
- F Avenir LT Std; 65 Medium; 7.5mm cap-height; Optical kerning; Tracking (0); Left aligned; White; Direct print or vinyl; (future)
- G Braille; 10mm cap-height; Colour to match panel; Raised 0.8mm from panel; Message to include both room name and room number
- H Pictogram; White; Raised 0.8mm from panel; Size relative to signage layout in scale
- I Pictogram; White; Direct print or vinyl; Size relative to signage layout in scale

Use

Sign for public amenity rooms, including pictogram, permanent description, braille translations, ie. stairs, washrooms.

Room ID with Insert - A

Standard

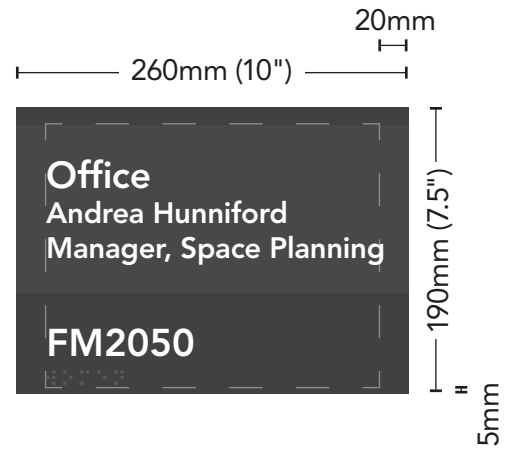

1 Layout

Scale: 1:5

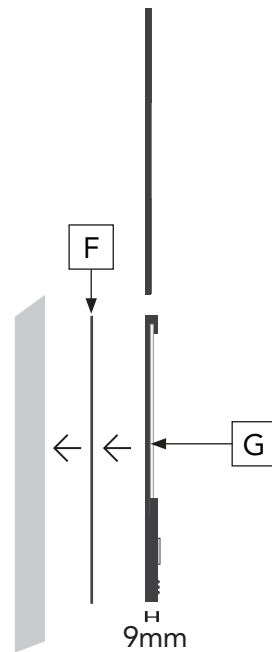
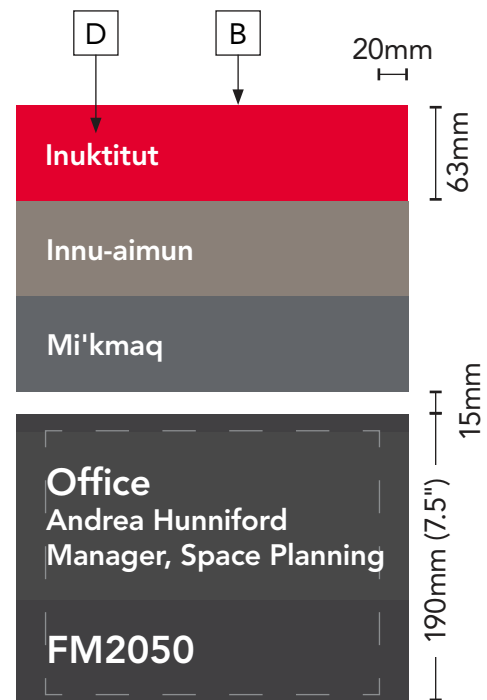

3 Section

Scale: 1:5

2 Layout: Translations

Scale: 1:5

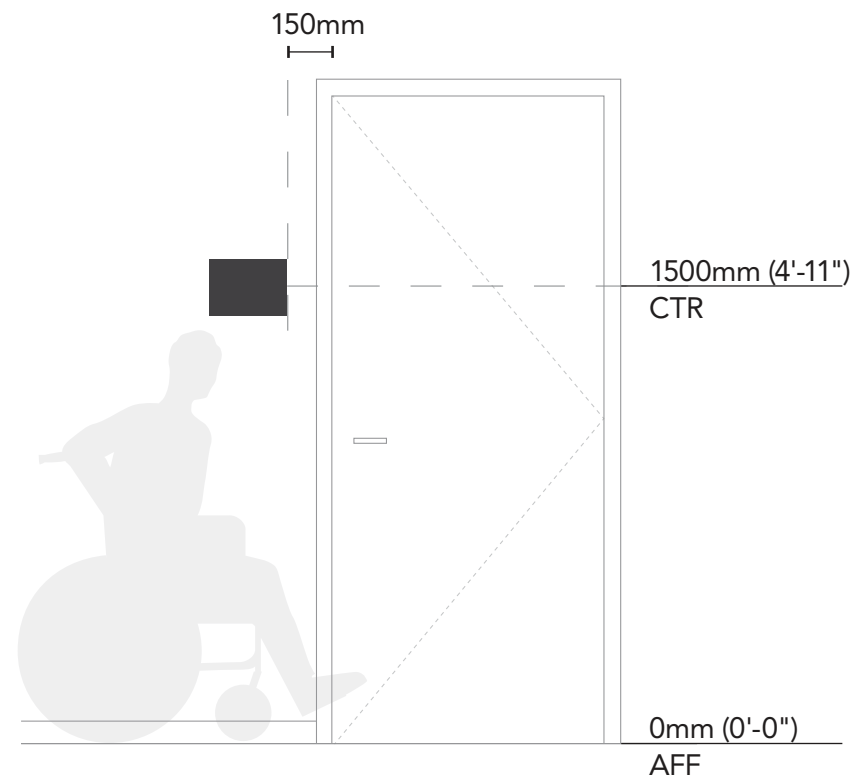

4 Elevation

Scale: 1:25

Description

- A** 9mm-thick acrylic panel; Charcoal colour; Returns to match panel colour; Mounted to wall surface securely
- B** 3mm-thick acrylic panel; Charcoal colour; Vinyl sticker with translation colour specifications applied to surface of panel; Mounted to wall surface securely
- C** Avenir LT Std; 85 Heavy; 18mm cap-height; Optical kerning; Tracking (0); Left aligned; White; Raised 0.8mm from panel (not on inserts)
- D** Avenir LT Std; 85 Heavy; 14mm cap-height; Optical kerning; Tracking (0); Left aligned; White; Printed
- E** Braille; 10mm cap-height; Colour to match panel; Raised 0.8mm from panel
- F** When mounted to glass surface, vinyl backer to be applied to same side of glass as sign to hide adhesive; Backer to match sign colour
- G** White cardstock insert printed with background to match panel

Use

Sign for offices and small meeting room identification, where a paper insert is used to identify the room type, perhaps the occupant, and capacity description, all as per the insert template.



1 Indigenous (future) Scale: NTS

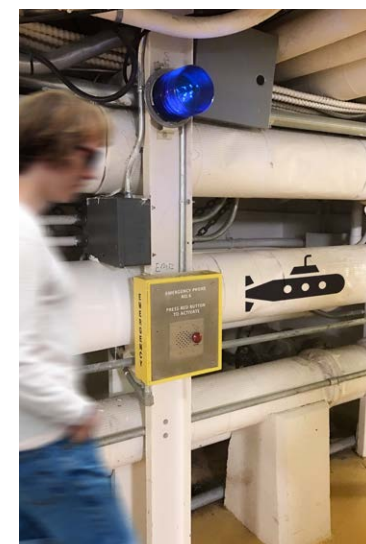

Description

A Die-cut vinyl decal; Charcoal or colour of choice; Size relative to signage layout in scale

Use

Use of Indigenous infographics and symbols are to be coordinated with the Office of Indigenous Affairs.